Section 17. 10-bit A/D Converter

HIGHLIGHTS

This section of the manual contains the following major topics:

17.1	Introduction	17-2
17.2	Control Registers	17-4
17.3	A/D Result Buffer	17-4
17.4	A/D Terminology and Conversion Sequence	17-11
17.5	A/D Module Configuration	17-13
17.6	Selecting the Voltage Reference Source	17-13
17.7	Selecting the A/D Conversion Clock	17-13
17.8	Selecting Analog Inputs for Sampling	17-14
17.9	Enabling the Module	17-16
17.10	Specifying the Sample/Conversion Sequence	17-16
17.11	How to Start Sampling	17-17
17.12	How to Stop Sampling and Start Conversions	17-18
17.13	Controlling Sample/Conversion Operation	17-29
17.14	Specifying How Conversion Results are Written Into the Buffer	17-30
17.15	Turning the A/D Module Off	17-30
17.16	Conversion Sequence Examples	17-31
17.17	A/D Sampling Requirements	17-45
17.18	Reading the A/D Result Buffer	17-46
17.19	Transfer Function	17-47
17.20	A/D Accuracy/Error	17-47
17.21	Connection Considerations	17-47
17.22	Initialization	17-48
17.23	A/D Conversion Speeds	17-49
17.24	Operation During Sleep and Idle Modes	17-55
17.25	Effects of a Reset	17-55
17.26	Special Function Registers Associated with the 10-bit A/D Converter	17-56
17.27	Design Tips	17-57
17.28	Related Application Notes	17-58
17.29	Revision History	17-59

17.1 Introduction

The dsPIC30F 10-bit A/D converter has the following key features:

- Successive Approximation Resistor (SAR) conversion
- Up to 1 Msp/s conversion speed
- Up to 16 analog input pins
- External voltage reference input pins
- Four unipolar differential S/H amplifiers
- Simultaneous sampling of up to four analog input pins
- Automatic Channel Scan mode
- Selectable conversion trigger source
- 16-word conversion result buffer
- Selectable Buffer Fill modes
- Four result alignment options
- Operation during CPU Sleep and Idle modes

A block diagram of the 10-bit A/D is shown in Figure 17-1. The 10-bit A/D converter can have up to 16 analog input pins, designated AN0-AN15. In addition, there are two analog input pins for external voltage reference connections. These voltage reference inputs may be shared with other analog input pins. The actual number of analog input pins and external voltage reference input configuration will depend on the specific dsPIC30F device. Refer to the device data sheet for further details.

The analog inputs are connected via multiplexers to four S/H amplifiers, designated CH0-CH3. One, two or four of the S/H amplifiers may be enabled for acquiring input data. The analog input multiplexers can be switched between two sets of analog inputs during conversions. Unipolar differential conversions are possible on all channels using certain input pins (see Figure 17-1).

An Analog Input Scan mode may be enabled for the CH0 S/H amplifier. A Control register specifies which analog input channels will be included in the scanning sequence.

The 10-bit A/D is connected to a 16-word result buffer. Each 10-bit result is converted to one of four 16-bit output formats when it is read from the buffer.

Figure 17-1: 10-Bit High-Speed A/D Block Diagram

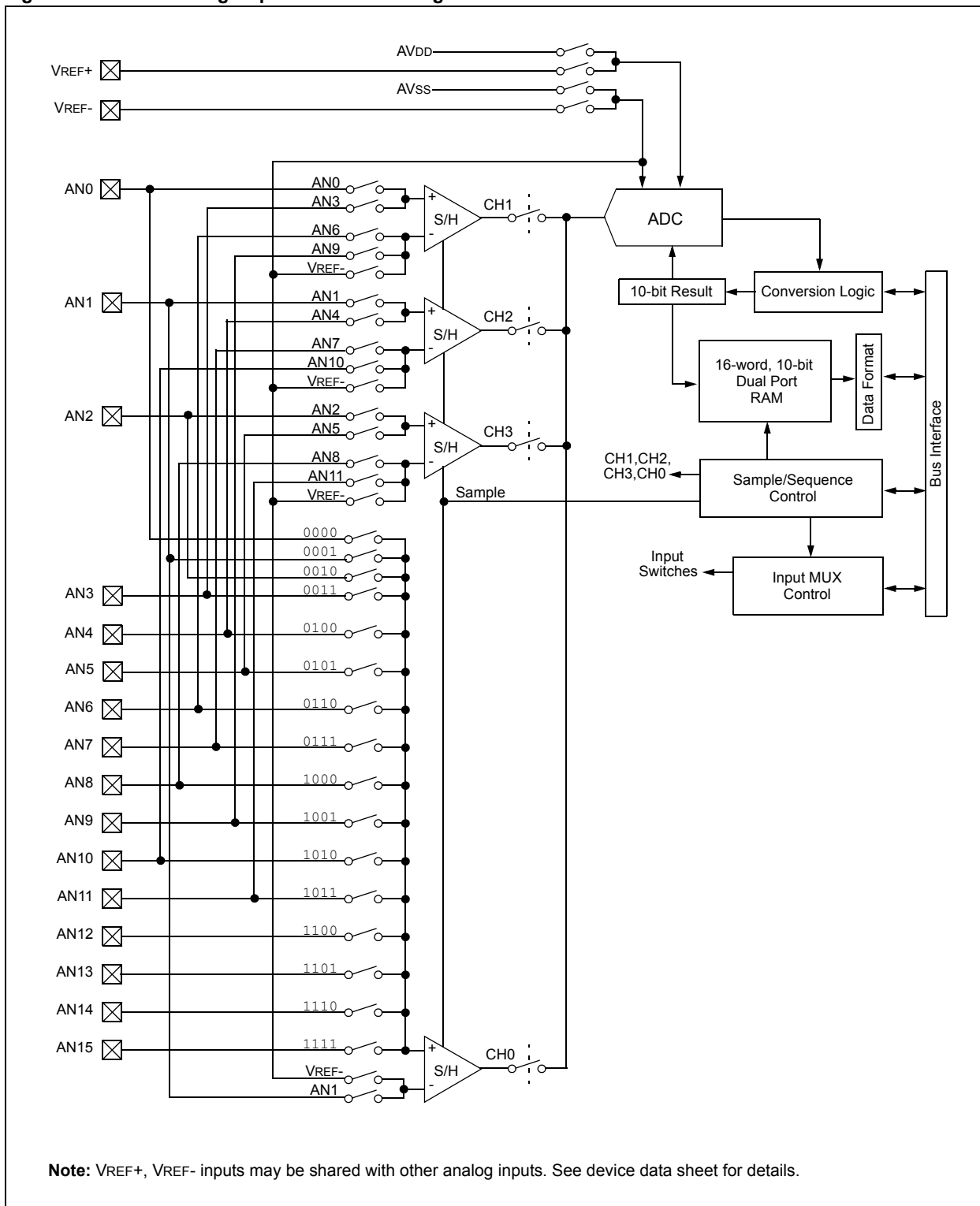

17.2 Control Registers

The A/D module has six Control and Status registers. These registers are:

- ADCON1: A/D Control Register 1
- ADCON2: A/D Control Register 2
- ADCON3: A/D Control Register 3
- ADCHS: A/D Input Channel Select Register
- ADPCFG: A/D Port Configuration Register
- ADCSSL: A/D Input Scan Select Register

The ADCON1, ADCON2 and ADCON3 registers control the operation of the A/D module. The ADCHS register selects the input pins to be connected to the S/H amplifiers. The ADPCFG register configures the analog input pins as analog inputs or as digital I/O. The ADCSSL register selects inputs to be sequentially scanned.

17.3 A/D Result Buffer

The module contains a 16-word dual port RAM, called ADCBUF, to buffer the A/D results. The 16 buffer locations are referred to as ADCBUF0, ADCBUF1, ADCBUF2, ..., ADCBUFE, ADCBUFF.

Note: The A/D result buffer is a read only buffer.

Register 17-1: ADCON1: A/D Control Register 1

Upper Byte:							
R/W-0	U-0	R/W-0	U-0	U-0	U-0	R/W-0	R/W-0
ADON	—	ADSIDL	—	—	—	FORM<1:0>	
bit 15						bit 8	

Lower Byte:							
R/W-0	R/W-0	R/W-0	U-0	R/W-0	R/W-0	R/W-0 HC, HS	R/C-0 HC, HS
SSRC<2:0>			—	SIMSAM	ASAM	SAMP	DONE
bit 7						bit 0	

- bit 15 **ADON:** A/D Operating Mode bit
 1 = A/D converter module is operating
 0 = A/D converter is off

- bit 14 **Unimplemented:** Read as '0'
- bit 13 **ADSIDL:** Stop in Idle Mode bit
 1 = Discontinue module operation when device enters Idle mode
 0 = Continue module operation in Idle mode

- bit 12-10 **Unimplemented:** Read as '0'
- bit 9-8 **FORM<1:0>:** Data Output Format bits
 11 = Signed Fractional (DOUT = sddd dddd dd00 0000)
 10 = Fractional (DOUT = dddd dddd dd00 0000)
 01 = Signed Integer (DOUT = ssss sssd dddd dddd)
 00 = Integer (DOUT = 0000 00dd dddd dddd)

- bit 7-5 **SSRC<2:0>:** Conversion Trigger Source Select bits
 111 = Internal counter ends sampling and starts conversion (auto convert)
 110 = Reserved
 101 = Reserved
 100 = Reserved
 011 = Motor Control PWM interval ends sampling and starts conversion
 010 = GP Timer3 compare ends sampling and starts conversion
 001 = Active transition on INT0 pin ends sampling and starts conversion
 000 = Clearing SAMP bit ends sampling and starts conversion

- bit 4 **Unimplemented:** Read as '0'
- bit 3 **SIMSAM:** Simultaneous Sample Select bit (only applicable when CHPS = 01 or 1x)
 1 = Samples CH0, CH1, CH2, CH3 simultaneously (when CHPS = 1x)
 or
 Samples CH0 and CH1 simultaneously (when CHPS = 01)
 0 = Samples multiple channels individually in sequence

- bit 2 **ASAM:** A/D Sample Auto-Start bit
 1 = Sampling begins immediately after last conversion completes. SAMP bit is auto set
 0 = Sampling begins when SAMP bit set

dsPIC30F Family Reference Manual

Register 17-1: ADCON1: A/D Control Register 1 (Continued)

- bit 1 **SAMP:** A/D Sample Enable bit
1 = At least one A/D sample/hold amplifier is sampling
0 = A/D sample/hold amplifiers are holding
When ASAM = 0, writing '1' to this bit will start sampling
When SSRC = 000, writing '0' to this bit will end sampling and start conversion
- bit 0 **DONE:** A/D Conversion Status bit (Rev. B silicon or later)
1 = A/D conversion is done
0 = A/D conversion is NOT done
Cleared by software or start of a new conversion
Clearing this bit will not effect any operation in progress

Legend:

R = Readable bit	W = Writable bit	U = Unimplemented bit, read as '0'
HC = Hardware clear	HS = Hardware set	C = Clearable by software
-n = Value at POR	'1' = Bit is set	'0' = Bit is cleared x = Bit is unknown

Register 17-2: ADCON2: A/D Control Register 2

Upper Byte:								
R/W-0	R/W-0	R/W-0	U-0	U-0	R/W-0	R/W-0	R/W-0	
VCFG<2:0>		reserved	—	CSCNA	CHPS<1:0>			
bit 15								bit 8

Lower Byte:							
R-0	U-0	R/W-0	R/W-0	R/W-0	R/W-0	R/W-0	R/W-0
BUFS	—	SMPI<3:0>				BUFM	ALTS
bit 7						bit 0	

bit 15-13 **VCFG<2:0>**: Voltage Reference Configuration bits

	A/D VREFH	A/D VREFL
000	AVDD	AVSS
001	External VREF+ pin	AVSS
010	AVDD	External VREF- pin
011	External VREF+ pin	External VREF- pin
1XX	AVDD	AVSS

bit 12 **Reserved:** User should write '0' to this location

bit 11 **Unimplemented:** Read as '0'

bit 10 **CSCNA:** Scan Input Selections for CH0+ S/H Input for MUX A Input Multiplexer Setting bit
 1 = Scan inputs
 0 = Do not scan inputs

bit 9-8 **CHPS<1:0>**: Selects Channels Utilized bits
 1x = Converts CH0, CH1, CH2 and CH3
 01 = Converts CH0 and CH1
 00 = Converts CH0
 When SIMSAM bit (ADCON1<3>) = 0 multiple channels sampled sequentially
 When SMSAM bit (ADCON1<3>) = 1 multiple channels sampled as in CHPS<1:0>

bit 7 **BUFS:** Buffer Fill Status bit
 Only valid when BUFM = 1 (ADRES split into 2 x 8-word buffers).
 1 = A/D is currently filling buffer 0x8-0xF, user should access data in 0x0-0x7
 0 = A/D is currently filling buffer 0x0-0x7, user should access data in 0x8-0xF

bit 6 **Unimplemented:** Read as '0'

bit 5-2 **SMPI<3:0>**: Sample/Convert Sequences Per Interrupt Selection bits
 1111 = Interrupts at the completion of conversion for each 16th sample/convert sequence
 1110 = Interrupts at the completion of conversion for each 15th sample/convert sequence

 0001 = Interrupts at the completion of conversion for each 2nd sample/convert sequence
 0000 = Interrupts at the completion of conversion for each sample/convert sequence

bit 1 **BUFM:** Buffer Mode Select bit
 1 = Buffer configured as two 8-word buffers ADCBUF(15...8), ADCBUF(7...0)
 0 = Buffer configured as one 16-word buffer ADCBUF(15...0)

bit 0 **ALTS:** Alternate Input Sample Mode Select bit
 1 = Uses MUX A input multiplexer settings for first sample, then alternate between MUX B and MUX A input multiplexer settings for all subsequent samples
 0 = Always use MUX A input multiplexer settings

Legend:			
R = Readable bit	W = Writable bit	U = Unimplemented bit, read as '0'	
-n = Value at POR	'1' = Bit is set	'0' = Bit is cleared	x = Bit is unknown

dsPIC30F Family Reference Manual

Register 17-3: ADCON3: A/D Control Register 3

Upper Byte:								
U-0	U-0	U-0	R/W-0	R/W-0	R/W-0	R/W-0	R/W-0	
—	—	—	SAMC<4:0>					
bit 15								bit 8

Lower Byte:								
R/W-0	U-0	R/W-0	R/W-0	R/W-0	R/W-0	R/W-0	R/W-0	
ADRC	—	ADCS<5:0>						
bit 7								bit 0

bit 15-13 **Unimplemented:** Read as '0'

bit 12-8 **SAMC<4:0>:** Auto-Sample Time bits

11111 = 31 TAD

.....

00001 = 1 TAD

00000 = 0 TAD (only allowed if performing sequential conversions using more than one S/H amplifier)

bit 7 **ADRC:** A/D Conversion Clock Source bit

1 = A/D internal RC clock

0 = Clock derived from system clock

bit 6 **Unimplemented:** Read as '0'

bit 5-0 **ADCS<5:0>:** A/D Conversion Clock Select bits

111111 = $T_{cy}/2 \cdot (ADCS<5:0> + 1) = 32 \cdot T_{cy}$

.....

000001 = $T_{cy}/2 \cdot (ADCS<5:0> + 1) = T_{cy}$

000000 = $T_{cy}/2 \cdot (ADCS<5:0> + 1) = T_{cy}/2$

Legend:

R = Readable bit

W = Writable bit

U = Unimplemented bit, read as '0'

-n = Value at POR

'1' = Bit is set

'0' = Bit is cleared

x = Bit is unknown

Register 17-4: ADCHS: A/D Input Channel Select Register

Upper Byte:							
R/W-0	R/W-0	R/W-0	R/W-0	R/W-0	R/W-0	R/W-0	R/W-0
CH123NB<1:0>		CH123SB	CH0NB	CH0SB<3:0>			
bit 15						bit 8	

Lower Byte:							
R/W-0	R/W-0	R/W-0	R/W-0	R/W-0	R/W-0	R/W-0	R/W-0
CH123NA<1:0>		CH123SA	CH0NA	CH0SA<3:0>			
bit 7						bit 0	

- bit 15-14 **CH123NB<1:0>**: Channel 1, 2, 3 Negative Input Select for MUX B Multiplexer Setting bits
Same definition as bits 6-7 (**Note**)
- bit 13 **CH123SB**: Channel 1, 2, 3 Positive Input Select for MUX B Multiplexer Setting bit
Same definition as bit 5 (**Note**)
- bit 12 **CH0NB**: Channel 0 Negative Input Select for MUX B Multiplexer Setting bit
Same definition as bit 4 (**Note**)
- bit 11-8 **CH0SB<3:0>**: Channel 0 Positive Input Select for MUX B Multiplexer Setting bits
Same definition as bits 3-0 (**Note**)
- bit 7-6 **CH123NA<1:0>**: Channel 1, 2, 3 Negative Input Select for MUX A Multiplexer Setting bits
11 = CH1 negative input is AN9, CH2 negative input is AN10, CH3 negative input is AN11
10 = CH1 negative input is AN6, CH2 negative input is AN7, CH3 negative input is AN8
0x = CH1, CH2, CH3 negative input is VREF-
- bit 5 **CH123SA**: Channel 1, 2, 3 Positive Input Select for MUX A Multiplexer Setting bit
1 = CH1 positive input is AN3, CH2 positive input is AN4, CH3 positive input is AN5
0 = CH1 positive input is AN0, CH2 positive input is AN1, CH3 positive input is AN2
- bit 4 **CH0NA**: Channel 0 Negative Input Select for MUX A Multiplexer Setting bit
1 = Channel 0 negative input is AN1
0 = Channel 0 negative input is VREF-
- bit 3-0 **CH0SA<3:0>**: Channel 0 Positive Input Select for MUX A Multiplexer Setting bits
1111 = Channel 0 positive input is AN15
1110 = Channel 0 positive input is AN14
1101 = Channel 0 positive input is AN13
.
.
.
0001 = Channel 0 positive input is AN1
0000 = Channel 0 positive input is AN0

Note: The analog input multiplexer supports two input setting configurations, denoted MUX A and MUX B. ADCHS<15:8> determine the settings for MUX B, and ADCHS<7:0> determine the settings for MUX A. Both sets of control bits function identically.

Note: The ADCHS register description and functionality will vary depending on the number of A/D inputs available on the selected device. Please refer to the specific device data sheet for additional details on this register.

Legend:			
R = Readable bit	W = Writable bit	U = Unimplemented bit, read as '0'	
-n = Value at POR	'1' = Bit is set	'0' = Bit is cleared	x = Bit is unknown

dsPIC30F Family Reference Manual

Register 17-5: ADPCFG: A/D Port Configuration Register

Upper Byte:							
R/W-0	R/W-0	R/W-0	R/W-0	R/W-0	R/W-0	R/W-0	R/W-0
PCFG15	PCFG14	PCFG13	PCFG12	PCFG11	PCFG10	PCFG9	PCFG8
bit 15							bit 8

Lower Byte:							
R/W-0	R/W-0	R/W-0	R/W-0	R/W-0	R/W-0	R/W-0	R/W-0
PCFG7	PCFG6	PCFG5	PCFG4	PCFG3	PCFG2	PCFG1	PCFG0
bit 7							bit 0

bit 15-0 **PCFG<15:0>**: Analog Input Pin Configuration Control bits
 1 = Analog input pin in Digital mode, port read input enabled, A/D input multiplexer input connected to AVss
 0 = Analog input pin in Analog mode, port read input disabled, A/D samples pin voltage

Legend:			
R = Readable bit	W = Writable bit	U = Unimplemented bit, read as '0'	
-n = Value at POR	'1' = Bit is set	'0' = Bit is cleared	x = Bit is unknown

Register 17-6: ADCSSL: A/D Input Scan Select Register

Upper Byte:							
R/W-0	R/W-0	R/W-0	R/W-0	R/W-0	R/W-0	R/W-0	R/W-0
CSSL15	CSSL14	CSSL13	CSSL12	CSSL11	CSSL10	CSSL9	CSSL8
bit 15							bit 8

Lower Byte:							
R/W-0	R/W-0	R/W-0	R/W-0	R/W-0	R/W-0	R/W-0	R/W-0
CSSL7	CSSL6	CSSL5	CSSL4	CSSL3	CSSL2	CSSL1	CSSL0
bit 7							bit 0

bit 15-0 **CSSL<15:0>**: A/D Input Pin Scan Selection bits
 1 = Select ANx for input scan
 0 = Skip ANx for input scan

Legend:			
R = Readable bit	W = Writable bit	U = Unimplemented bit, read as '0'	
-n = Value at POR	'1' = Bit is set	'0' = Bit is cleared	x = Bit is unknown

17.4 A/D Terminology and Conversion Sequence

Figure 17-2 shows a basic conversion sequence and the terms that are used. A sampling of the analog input pin voltage is performed by sample and hold S/H amplifiers. The S/H amplifiers are also called S/H channels. The 10-bit A/D converter has four total S/H channels, designated CH0-CH3. The S/H channels are connected to the analog input pins via the analog input multiplexer. The analog input multiplexer is controlled by the ADCHS register. There are two sets of multiplexer control bits in the ADCHS register that function identically. These two sets of control bits allow two different analog input multiplexer configurations to be programmed, which are called MUX A and MUX B. The A/D converter can optionally switch between the MUX A and MUX B configurations between conversions. The A/D converter can also optionally scan through a series of analog inputs.

Sample time is the time that the A/D module's S/H amplifier is connected to the analog input pin. The sample time may be started manually by setting the SAMP bit (ADCON1<1>) or started automatically by the A/D converter hardware. The sample time is ended manually by clearing the SAMP control bit in the user software or automatically by a conversion trigger source.

Conversion time is the time required for the A/D converter to convert the voltage held by the S/H amplifier. The A/D is disconnected from the analog input pin at the end of the sample time. The A/D converter requires one A/D clock cycle (T_{AD}) to convert each bit of the result plus one additional clock cycle. A total of 12 T_{AD} cycles are required to perform the complete conversion. When the conversion time is complete, the result is loaded into one of 16 A/D Result registers (ADCBUF0...ADCBUFF), the S/H can be reconnected to the input pin, and a CPU interrupt may be generated.

The sum of the sample time and the A/D conversion time provides the total conversion time. There is a minimum sample time to ensure that the S/H amplifier will give the desired accuracy for the A/D conversion (see **Section 17.17 "A/D Sampling Requirements"**). Furthermore, there are multiple input clock options for the A/D converter. The user must select an input clock option that does not violate the minimum T_{AD} specification.

Figure 17-2: A/D Sample/Conversion Sequence

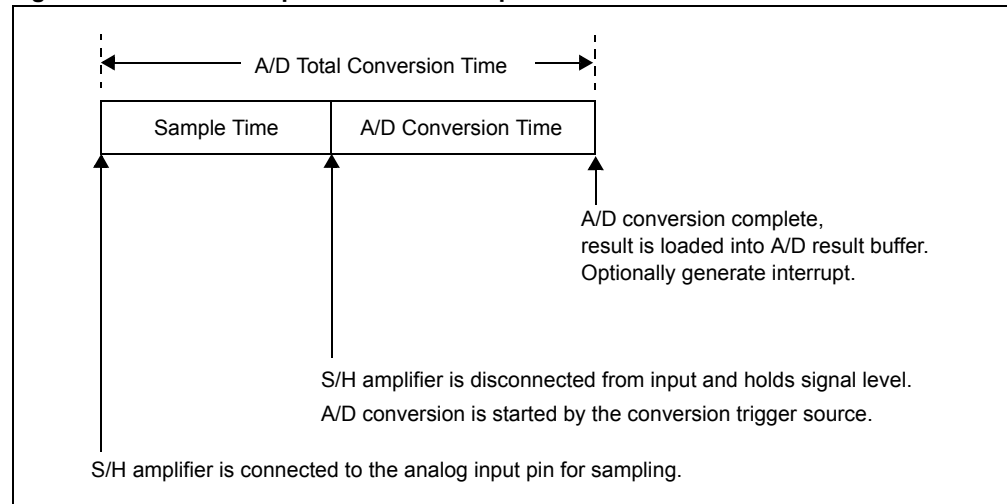

The 10-bit A/D converter allows many options for specifying the sample/convert sequence. The sample/convert sequence can be very simple, such as the one shown in Figure 17-3. The example in Figure 17-3 uses only one S/H amplifier. A more elaborate sample/convert sequence performs multiple conversions using more than one S/H amplifier. The 10-bit A/D converter can use two S/H amplifiers to perform two conversions in a sample/convert sequence or four S/H amplifiers with four conversions. The number of S/H amplifiers, or channels per sample, used in the sample/convert sequence is determined by the CHPS control bits.

A sample/convert sequence that uses multiple S/H channels can be simultaneously sampled or sequentially sampled, as controlled by the SIMSAM bit (ADCON1<3>). Simultaneously sampling multiple signals ensures that the snapshot of the analog inputs occurs at precisely the same time for all inputs. Sequential sampling takes a snapshot of each analog input just before conversion starts on that input, and the sampling of multiple inputs is not correlated.

Figure 17-3: Simultaneous and Sequential Sampling

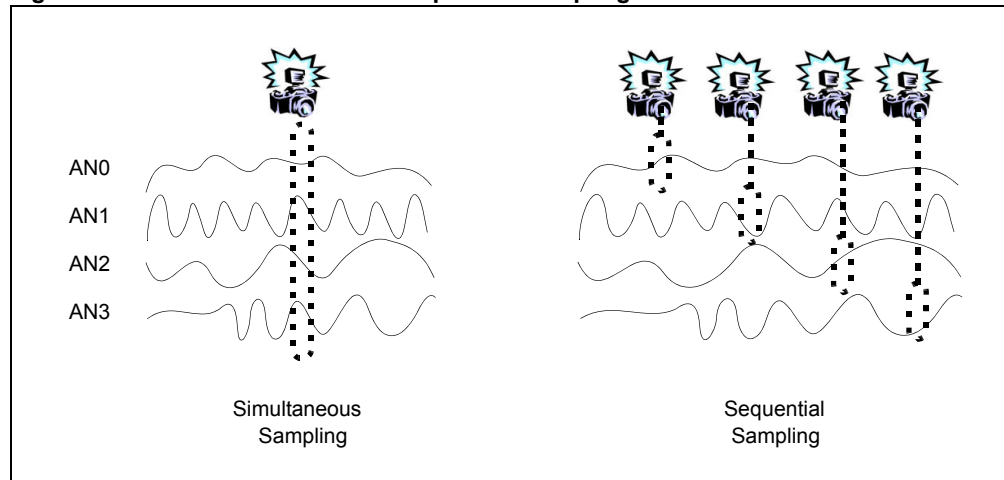

The start time for sampling can be controlled in software by setting the SAMP control bit. The start of the sampling time can also be controlled automatically by the hardware. When the A/D converter operates in the Auto-Sample mode, the S/H amplifier(s) is reconnected to the analog input pin at the end of the conversion in the sample/convert sequence. The auto-sample function is controlled by the ASAM control bit (ADCON1<2>).

The conversion trigger source ends the sampling time and begins an A/D conversion or a sample/convert sequence. The conversion trigger source is selected by the SSRC control bits. The conversion trigger can be taken from a variety of hardware sources, or can be controlled manually in software by clearing the SAMP control bit. One of the conversion trigger sources is an auto-conversion. The time between auto-conversions is set by a counter and the A/D clock. The Auto-Sample mode and auto-conversion trigger can be used together to provide endless automatic conversions without software intervention.

An interrupt may be generated at the end of each sample/convert sequence or multiple sample/convert sequences as determined by the value of the SMPI control bits ADCON2<5:2>. The number of sample/convert sequences between interrupts can vary between 1 and 16. The user should note that the A/D conversion buffer holds 16 results when the SMPI value is selected. The total number of conversion results between interrupts is the product of the channels per sample and the SMPI value. The total number of conversions between interrupts should not exceed the buffer length.

17.5 A/D Module Configuration

The following steps should be followed for performing an A/D conversion:

1. Configure the A/D module
 - Select port pins as analog inputs ADPCFG<15:0>
 - Select voltage reference source to match expected range on analog inputs ADCON2<15:13>
 - Select the analog conversion clock to match desired data rate with processor clock ADCON3<5:0>
 - Determine how many S/H channels will be used ADCON2<9:8> and ADPCFG<15:0>
 - Determine how sampling will occur ADCON1<3> and ADCSSL<15:0>
 - Determine how inputs will be allocated to S/H channels ADCHS<15:0>
 - Select the appropriate sample/conversion sequence ADCON1<7:0> and ADCON3<12:8>
 - Select how conversion results are presented in the buffer ADCON1<9:8>
 - Select interrupt rate ADCON2<5:9>
 - Turn on A/D module ADCON1<15>
2. Configure A/D interrupt (if required)
 - Clear ADIF bit
 - Select A/D interrupt priority

The options for each configuration step are described in the subsequent sections.

17.6 Selecting the Voltage Reference Source

The voltage references for A/D conversions are selected using the VCFG<2:0> control bits (ADCON2<15:13>). The upper voltage reference (VREFH) and the lower voltage reference (VREFL) may be the internal AVDD and AVSS voltage rails or the VREF+ and VREF- input pins.

The external voltage reference pins may be shared with the AN0 and AN1 inputs on low pin count devices. The A/D converter can still perform conversions on these pins when they are shared with the VREF+ and VREF- input pins.

The voltages applied to the external reference pins must meet certain specifications. Refer to the “Electrical Specifications” section of the device data sheet for further details.

Note: External VREF+ and VREF- must be selected for conversion rates above 500 ksp/s. See **Section 17.23 “A/D Conversion Speeds”** for further details.

17.7 Selecting the A/D Conversion Clock

The A/D converter has a maximum rate at which conversions may be completed. An analog module clock, TAD, controls the conversion timing. The A/D conversion requires 12 clock periods (12 TAD). The A/D clock is derived from the device instruction clock or internal RC clock source.

The period of the A/D conversion clock is software selected using a six-bit counter. There are 64 possible options for TAD, specified by the ADCS<5:0> bits (ADCON3<5:0>). Equation 17-1 gives the TAD value as a function of the ADCS control bits and the device instruction cycle clock period, TCY.

Equation 17-1: A/D Conversion Clock Period

$$T_{AD} = \frac{T_{CY}(ADCS + 1)}{2}$$

$$ADCS = \frac{2T_{AD}}{T_{CY}} - 1$$

For correct A/D conversions, the A/D conversion clock (TAD) must be selected to ensure a minimum TAD time of 83.33 nsec (see **Section 17.23 “A/D Conversion Speeds”** for further details).

The A/D converter has a dedicated internal RC clock source that can be used to perform conversions. The internal RC clock source should be used when A/D conversions are performed while the dsPIC30F is in Sleep mode. The internal RC oscillator is selected by setting the ADRC bit (ADCON3<7>). When the ADRC bit is set, the ADCS<5:0> bits have no effect on the A/D operation.

17.8 Selecting Analog Inputs for Sampling

All Sample-and-Hold Amplifiers have analog multiplexers (see Figure 17-1) on both their non-inverting and inverting inputs to select which analog input(s) are sampled. Once the sample/convert sequence is specified, the ADCHS bits determine which analog inputs are selected for each sample.

Additionally, the selected inputs may vary on an alternating sample basis or may vary on a repeated sequence of samples.

The same analog input can be connected to two or more sample and hold channels to improve conversion rates.

Note: Different devices will have different numbers of analog inputs. Verify the analog input availability against the device data sheet.

17.8.1 Configuring Analog Port Pins

The ADPCFG register specifies the input condition of device pins used as analog inputs.

A pin is configured as analog input when the corresponding PCFGn bit (ADPCFG<n>) is clear. The ADPCFG register is clear at Reset, causing the A/D input pins to be configured for analog input by default at Reset.

When configured for analog input, the associated port I/O digital input buffer is disabled so it does not consume current.

The ADPCFG register and the TRISB register control the operation of the A/D port pins.

The port pins that are desired as analog inputs must have their corresponding TRIS bit set, specifying port input. If the I/O pin associated with an A/D input is configured as an output, TRIS bit is cleared and the ports digital output level (VOH or VOL) will be converted. After a device Reset, all TRIS bits are set.

A pin is configured as digital I/O when the corresponding PCFGn bit (ADPCFG<n>) is set. In this configuration, the input to the analog multiplexer is connected to AVss.

Note 1: When reading the A/D Port register, any pin configured as an analog input reads as a '0'.
2: Analog levels on any pin that is defined as a digital input (including the AN15:AN0 pins) may cause the input buffer to consume current that is out of the device's specification.

17.8.2 Channel 0 Input Selection

Channel 0 is the most flexible of the 4 S/H channels in terms of selecting analog inputs.

The user may select any of the up to 16 analog inputs as the input to the positive input of the channel. The CH0SA<3:0> bits (ADCHS<3:0>) normally select the analog input for the positive input of channel 0.

The user may select either VREF- or AN1 as the negative input of the channel. The CH0NA bit (ADCHS<4>) normally selects the analog input for the negative input of channel 0.

17.8.2.1 Specifying Alternating Channel 0 Input Selections

The ALTS bit (ADCON2<0>) causes the module to alternate between two sets of inputs that are selected during successive samples.

The inputs specified by CH0SA<3:0>, CH0NA, CHXSA and CHXNA<1:0> are collectively called the MUX A inputs. The inputs specified by CH0SB<3:0>, CH0NB, CHXSB and CHXNB<1:0> are collectively called the MUX B inputs. When the ALTS bit is '1', the module will alternate between the MUX A inputs on one sample and the MUX B inputs on the subsequent sample.

For channel 0, if the ALTS bit is '0', only the inputs specified by CH0SA<3:0> and CH0NA are selected for sampling.

If the ALTS bit is '1', on the first sample/convert sequence for channel 0, the inputs specified by CH0SA<3:0> and CH0NA are selected for sampling. On the next sample convert sequence for channel 0, the inputs specified by CH0SB<3:0> and CH0NB are selected for sampling. This pattern will repeat for subsequent sample conversion sequences.

Note that if multiple channels (CHPS = 01 or 1x) and simultaneous sampling (SIMSAM = 1) are specified, alternating inputs will change every sample because all channels are sampled on every sample time. If multiple channels (CHPS = 01 or 1x) and sequential sampling (SIMSAM = 0) are specified, alternating inputs will change only on each sample of a particular channel.

17.8.2.2 Scanning Through Several Inputs with Channel 0

Channel 0 has the ability to scan through a selected vector of inputs. The CSCNA bit (ADCON2<10>) enables the CH0 channel inputs to be scanned across a selected number of analog inputs. When CSCNA is set, the CH0SA<3:0> bits are ignored.

The ADCSSL register specifies the inputs to be scanned. Each bit in the ADCSSL register corresponds to an analog input. Bit 0 corresponds to AN0, bit 1 corresponds to AN1 and so on. If a particular bit in the ADCSSL register is '1', the corresponding input is part of the scan sequence. The inputs are always scanned from lower to higher numbered inputs, starting at the first selected channel after each interrupt occurs.

Note: If the number of scanned inputs selected is greater than the number of samples taken per interrupt, the higher numbered inputs will not be sampled.
--

The ADCSSL bits only specify the input of the positive input of the channel. The CH0NA bit still selects the input of the negative input of the channel during scanning.

If the ALTS bit is '1', the scanning only applies to the MUX A input selection. The MUX B input selection, as specified by the CH0SB<3:0>, will still select the alternating channel 0 input. When the input selections are programmed in this manner, the channel 0 input will alternate between a set of scanning inputs specified by the ADCSSL register and a fixed input specified by the CH0SB bits.

17.8.3 Channel 1, 2 and 3 Input Selection

Channel 1, 2 and 3 can sample a subset of the analog input pins. Channel 1, 2 and 3 may select one of two groups of 3 inputs.

The CHXSA bit (ADCHS<5>) selects the source for the positive inputs of channel 1, 2 and 3.

Clearing CHXSA selects AN0, AN1 and AN2 as the analog source to the positive inputs of channel 1, 2 and 3, respectively. Setting CHXSA selects AN3, AN4 and AN5 as the analog source.

The CHXNA<1:0> bits (ADCHS<7:6>) select the source for the negative inputs of channel 1, 2 and 3.

Programming CHXNA = 0x, selects VREF- as the analog source for the negative inputs of channel 1, 2 and 3. Programming CHXNA = 10 selects AN6, AN7 and AN8 as the analog source to the negative inputs of channel 1, 2 and 3, respectively. Programming CHXNA = 11 selects AN9, AN10 and AN11 as the analog source.

17.8.3.1 Selecting Multiple Channels for a Single Analog Input

The analog input multiplexer can be configured so that the same input pin is connected to two or more sample and hold channels. The A/D converts the value held on one S/H channel, while the second S/H channel acquires a new input sample.

17.8.3.2 Specifying Alternating Channel 1, 2 and 3 Input Selections

As with the channel 0 inputs, the ALTS bit (ADCON2<0>) causes the module to alternate between two sets of inputs that are selected during successive samples for channel 1,2 and 3.

The MUX A inputs specified by CHXSA and CHXNA<1:0> always select the input when ALTS = 0.

The MUX A inputs alternate with the MUX B inputs specified by CHXSB and CHXNB<1:0> when ALTS = 1.

17.9 Enabling the Module

When the ADON bit (ADCON1<15>) is '1', the module is in Active mode and is fully powered and functional.

When ADON is '0', the module is disabled. The digital and analog portions of the circuit are turned off for maximum current savings.

In order to return to the Active mode from the Off mode, the user must wait for the analog stages to stabilize. For the stabilization time, refer to the Electrical Characteristics section of the device data sheet.

Note: The SSRC<2:0>, SIMSAM, ASAM, CHPS<1:0>, SMP1<3:0>, BUFM and ALTS bits, as well as the ADCON3 and ADCSSL registers, should not be written to while ADON = 1. This would lead to indeterminate results.
--

17.10 Specifying the Sample/Conversion Sequence

The 10-bit A/D module has 4 sample/hold amplifiers and one A/D converter. The module may perform 1, 2 or 4 input samples and A/D conversions per sample/convert sequence.

17.10.1 Number of Sample/Hold Channels

The CHPS<1:0> control bits (ADCON2<9:8>) are used to select how many S/H amplifiers are used by the A/D module during sample/conversion sequences. The following three options may be selected:

- CH0 only
- CH0 and CH1
- CH0, CH1, CH2, CH3

The CHPS control bits work in conjunction with the SIMSAM (simultaneous sample) control bit (ADCON1<3>).

17.10.2 Simultaneous Sampling Enable

Some applications may require that multiple signals are sampled at the exact same time instance. The SIMSAM control bit (ADCON1<3>) works in conjunction with the CHPS control bits and controls the sample/convert sequence for multiple channels as shown in Table 17-1. The SIMSAM control bit has no effect on the module operation if CHPS<1:0> = 00. If more than one S/H amplifier is enabled by the CHPS control bits and the SIMSAM bit is '0', the two or four selected channels are sampled and converted sequentially with two or four sampling periods. If the SIMSAM bit is '1', two or four selected channels are sampled simultaneously with one sampling period. The channels are then converted sequentially.

Table 17-1: Sample/Conversion Control Options

CHPS<1:0>	SIMSAM	Sample/Conversion Sequence	# of Sample/Convert Cycles to Complete	Example
00	x	Sample CH0, Convert CH0	1	Figure 17-4, Figure 17-5, Figure 17-6, Figure 17-7, Figure 17-10, Figure 17-11, Figure 17-14, Figure 17-15
01	0	Sample CH0, Convert CH0 Sample CH1, Convert CH1	2	—
1x	0	Sample CH0, Convert CH0 Sample CH1, Convert CH1 Sample CH2, Convert CH2 Sample CH3, Convert CH3	4	Figure 17-9, Figure 17-13, Figure 17-20
01	1	Sample CH0, CH1 simultaneously Convert CH0 Convert CH1	1	Figure 17-18
1x	1	Sample CH0, CH1, CH2, CH3 simultaneously Convert CH0 Convert CH1 Convert CH2 Convert CH3	1	Figure 17-8 Figure 17-12, Figure 17-16, Figure 17-17, Figure 17-9

17.11 How to Start Sampling

17.11.1 Manual

Setting the SAMP bit (ADCON1<1>) causes the A/D to begin sampling. One of several options can be used to end sampling and complete the conversions. Sampling will not resume until the SAMP bit is once again set. For an example, see Figure 17-4.

17.11.2 Automatic

Setting the ASAM bit (ADCON1<2>) causes the A/D to automatically begin sampling a channel whenever a conversion is not active on that channel. One of several options can be used to end sampling and complete the conversions. If the SIMSAM bit specifies sequential sampling, sampling on a channel resumes after the conversion of that channel completes. If the SIMSAM bit specifies simultaneous sampling, sampling on a channel resumes after the conversion of all channels completes. For an example, see Figure 17-5.

The ASAM bit should not be modified while the A/D converter is turned on. If automatic sampling is desired, the ASAM bit must be set before turning the module on. The A/D module does take some amount of time to stabilize (see the T_{PDU} parameter in the device datasheet), therefore, if automatic sampling is enabled, there is no guarantee than the first ADC result will be correct until the ADC module stabilizes. It may be necessary to discard the first ADC result depending on the A/D clock speed.

17.12 How to Stop Sampling and Start Conversions

The conversion trigger source will terminate sampling and start a selected sequence of conversions. The SSRC<2:0> bits (ADCON1<7:5>) select the source of the conversion trigger.

Note: The available conversion trigger sources may vary depending on the dsPIC30F device variant. Please refer to the specific device data sheet for the available conversion trigger sources.

Note: The SSRC selection bits should not be changed when the A/D module is enabled. If the user wishes to change the conversion trigger source, the A/D module should be disabled first by clearing the ADON bit (ADCON1<15>).

17.12.1 Manual

When SSRC<2:0> = 000, the conversion trigger is under software control. Clearing the SAMP bit (ADCON1<1>) starts the conversion sequence.

Figure 17-4 is an example where setting the SAMP bit initiates sampling and clearing the SAMP bit terminates sampling and starts conversion. The user software must time the setting and clearing of the SAMP bit to ensure adequate sampling time of the input signal. See Example 17-1 for code example.

Figure 17-4: Converting 1 Channel, Manual Sample Start, Manual Conversion Start

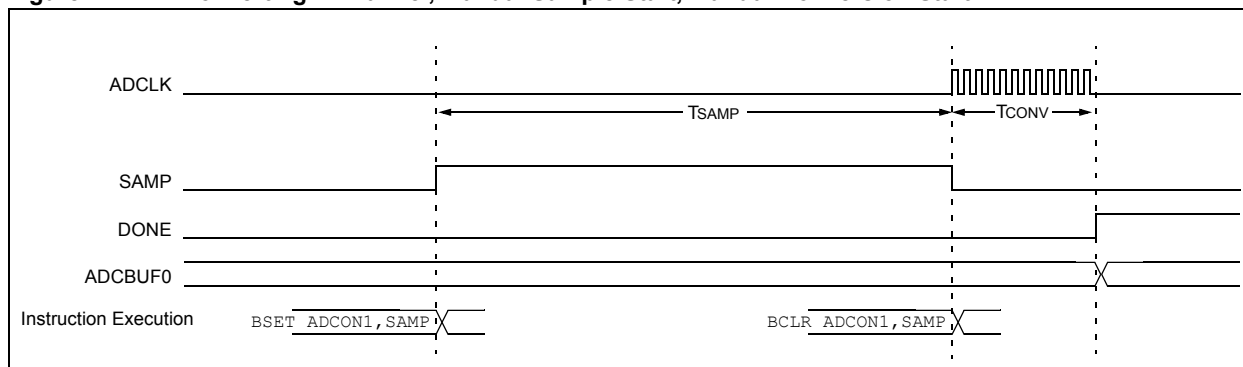

Example 17-1: Converting 1 Channel, Manual Sample Start, Manual Conversion Start Code

```

ADPCFG = 0xFFFFB;           // all PORTB = Digital; RB2 = analog
ADCON1 = 0x0000;           // SAMP bit = 0 ends sampling ...
                             // and starts converting
ADCHS  = 0x0002;           // Connect RB2/AN2 as CH0 input ..
                             // in this example RB2/AN2 is the input
ADCSSL = 0;
ADCON3 = 0x0002;           // Manual Sample, Tad = internal 2 Tcy
ADCON2 = 0;

ADCON1bits.ADON = 1;       // turn ADC ON
while (1)                  // repeat continuously
{
    ADCON1bits.SAMP = 1;   // start sampling ...
    DelayNmSec(100);      // for 100 mS
    ADCON1bits.SAMP = 0;   // start Converting
    while (!ADCON1bits.DONE); // conversion done?
    ADCValue = ADCBUF0;    // yes then get ADC value
}                           // repeat
    
```

Figure 17-5 is an example where setting the ASAM bit initiates automatic sampling and clearing the SAMP bit terminates sampling and starts conversion. After the conversion completes, the module will automatically return to a sampling state. The SAMP bit is automatically set at the start of the sample interval. The user software must time the clearing of the SAMP bit to ensure adequate sampling time of the input signal, understanding that the time between clearing of the SAMP bit includes the conversion time as well as the sampling time. See Example 17-2 for code example.

Figure 17-5: Converting 1 Channel, Automatic Sample Start, Manual Conversion Start

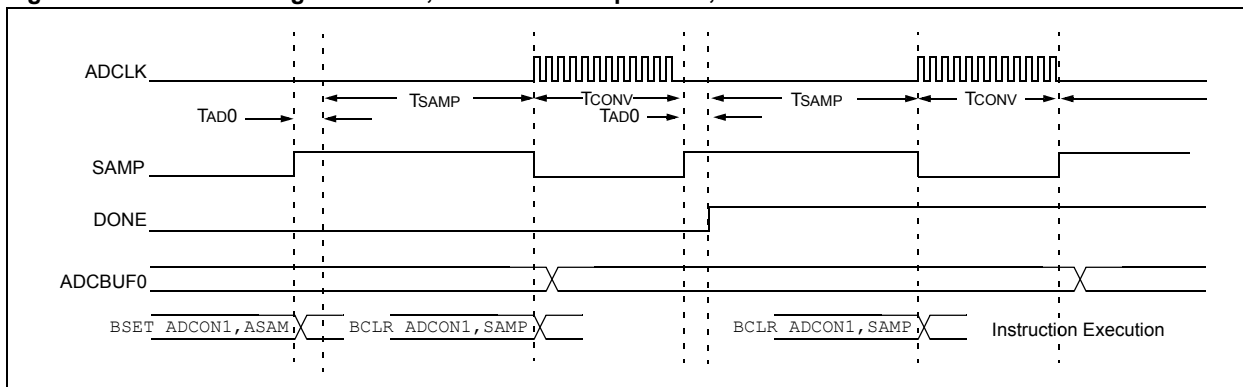

Example 17-2: Converting 1 Channel, Automatic Sample Start, Manual Conversion Start Code

```

ADPCFG = 0xFF7F;           // all PORTB = Digital but RB7 = analog
ADCON1 = 0x0004;           // ASAM bit = 1 implies sampling ..
                           // starts immediately after last
                           // conversion is done

ADCHS = 0x0007;           // Connect RB7/AN7 as CH0 input ..
                           // in this example RB7/AN7 is the input

ADCSSL = 0;
ADCON3 = 0x0002;           // Sample time manual, Tad = internal 2 Tcy
ADCON2 = 0;

ADCON1bits.ADON = 1;       // turn ADC ON
while (1)                  // repeat continuously
{
    DelayNmSec(100);       // sample for 100 mS
    ADCON1bits.SAMP = 0;   // start Converting
    while (!ADCON1bits.DONE); // conversion done?
    ADCValue = ADCBUF0;    // yes then get ADC value
}
    
```

17.12.2 Clocked Conversion Trigger

When $SSRC\langle 2:0 \rangle = 111$, the conversion trigger is under A/D clock control. The SAMC bits ($ADCON3\langle 12:8 \rangle$) select the number of T_{AD} clock cycles between the start of sampling and the start of conversion. This trigger option provides the fastest conversion rates on multiple channels. After the start of sampling, the module will count a number of T_{AD} clocks specified by the SAMC bits.

Equation 17-2: Clocked Conversion Trigger Time

$$T_{SMP} = SAMC\langle 4:0 \rangle * T_{AD}$$

When using only 1 S/H channel or simultaneous sampling, SAMC must always be programmed for at least one clock cycle. When using multiple S/H channels with sequential sampling, programming SAMC for zero clock cycles will result in the fastest possible conversion rate. See Example 17-3 for code example.

Figure 17-6: Converting 1 Channel, Manual Sample Start, TAD Based Conversion Start

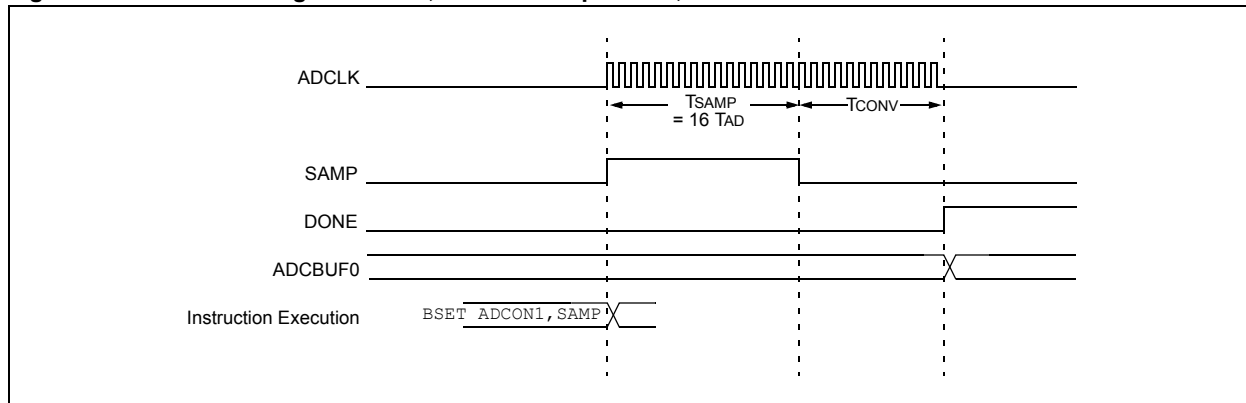

Example 17-3: Converting 1 Channel, Manual Sample Start, TAD Based Conversion Start Code

```

ADPCFG = 0xEFFF;           // all PORTB = Digital; RB12 = analog
ADCON1 = 0x00E0;           // SSRC bit = 111 implies internal
                             // counter ends sampling and starts
                             // converting.
ADCHS  = 0x000C;           // Connect RB12/AN12 as CH0 input ..
                             // in this example RB12/AN12 is the input
ADCSSL = 0;
ADCON3 = 0x1F02;           // Sample time = 31Tad, Tad = internal 2 Tcy
ADCON2 = 0;

ADCON1bits.ADON = 1;       // turn ADC ON
while (1)                  // repeat continuously
{
    ADCON1bits.SAMP = 1;   // start sampling then ...
                             // after 31Tad go to conversion
    while (!ADCON1bits.DONE); // conversion done?
    ADCValue = ADCBUF0;    // yes then get ADC value
}                           // repeat
    
```

17.12.2.1 Free Running Sample Conversion Sequence

As shown in Figure 17-7, using the Auto-Convert Conversion Trigger mode (SSRC = 111) in combination with the Auto-Sample Start mode (ASAM = 1), allows the A/D module to schedule sample/conversion sequences with no intervention by the user or other device resources. This “Clocked” mode allows continuous data collection after module initialization. See Example 17-4 for code example.

Note: This A/D configuration must be enabled for the conversion rate of 750 ksps (see Section 17.23 “A/D Conversion Speeds” for details).

Figure 17-7: Converting 1 Channel, Auto-Sample Start, TAD Based Conversion Start

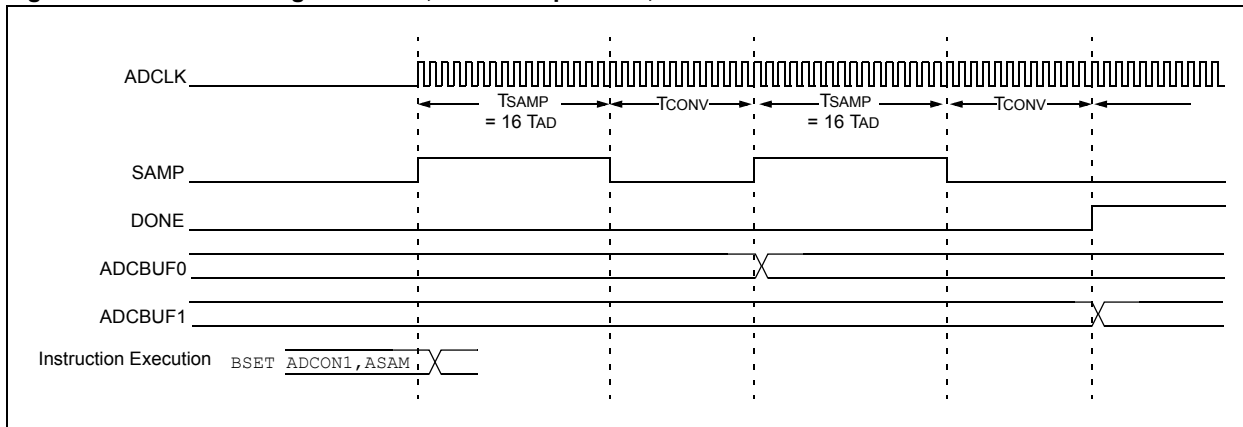

Example 17-4: Converting 1 Channel, Auto-Sample Start, TAD Based Conversion Start Code

```

ADPCFG = 0xFFFB;           // all PORTB = Digital; RB2 = analog
ADCON1 = 0x00E0;           // SSRC bit = 111 implies internal
                             // counter ends sampling and starts
                             // converting.
ADCHS  = 0x0002;           // Connect RB2/AN2 as CH0 input ..
                             // in this example RB2/AN2 is the input
ADCSSL = 0;
ADCON3 = 0x0F00;           // Sample time = 15Tad, Tad = internal Tcy/2
ADCON2 = 0x0004;           // Interrupt after every 2 samples

ADCON1bits.ADON = 1;       // turn ADC ON
while (1)                   // repeat continuously
{
    ADCValue = 0;           // clear value
    ADC16Ptr = &ADCBUF0;   // initialize ADCBUF pointer
    IFS0bits.ADIF = 0;     // clear ADC interrupt flag
    ADCON1bits.ASAM = 1;   // auto start sampling
                             // for 31Tad then go to conversion
    while (!IFS0bits.ADIF); // conversion done?
    ADCON1bits.ASAM = 0;   // yes then stop sample/convert
    for (count = 0; count < 2; count++) // average the 2 ADC value
        ADCValue = ADCValue + *ADC16Ptr++;
    ADCValue = ADCValue >> 1;
}
    
```

dsPIC30F Family Reference Manual

17.12.2.2 Multiple Channels with Simultaneous Sampling

As shown in Figure 17-8 when using simultaneous sampling, the SAMC value specifies the sampling time. In the example, SAMC specifies a sample time of 3 TAD. Because automatic sample start is active, sampling will start on all channels after the last conversion ends and will continue for 3 A/D clocks. See Example 17-5 for code example.

Figure 17-8: Converting 4 Channels, Auto-Sample Start, TAD Conversion Start, Simultaneous Sampling

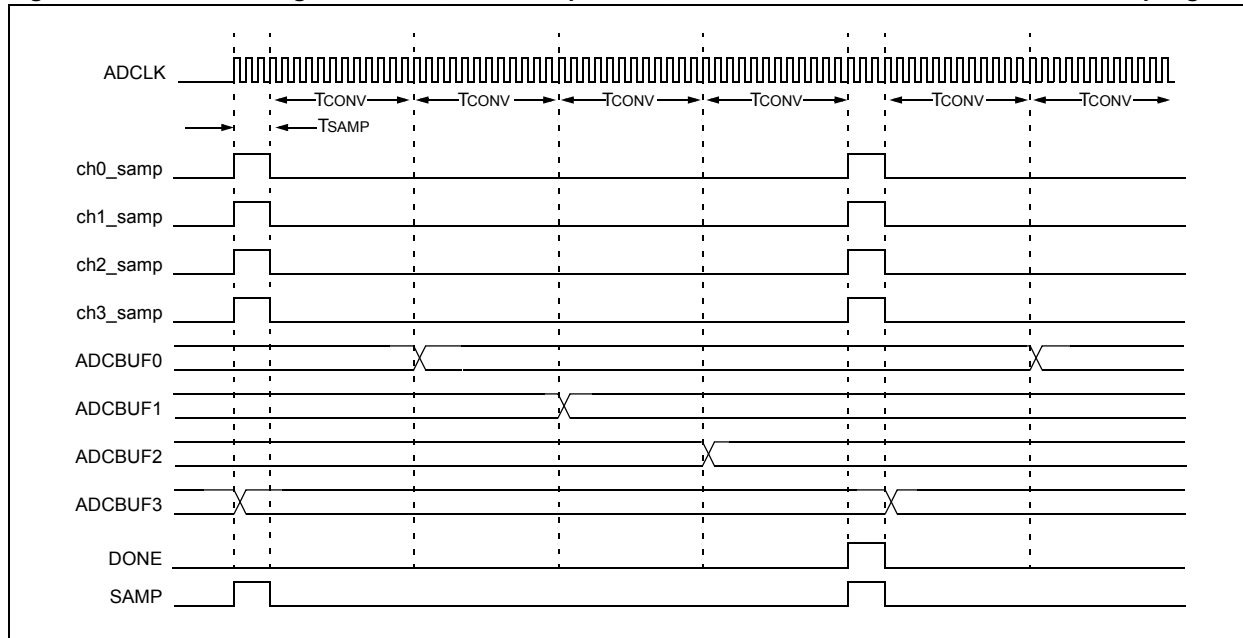

Example 17-5: Converting 4 Channels, Auto-Sample Start, TAD Conversion Start, Simultaneous Sampling Code

```
ADPCFG = 0xFF78;           // RB0,RB1,RB2 & RB7 = analog
ADCON1 = 0x00EC;          // SIMSAM bit = 1 implies ...
                           // simultaneous sampling
                           // ASAM = 1 for auto sample after convert
                           // SSRC = 111 for 3Tad sample time
ADCHS  = 0x0007;          // Connect AN7 as CH0 input

ADCSSL = 0;
ADCON3 = 0x0302;          // Auto Sampling 3 Tad, Tad = internal 2 Tcy
ADCON2 = 0x030C;          // CHPS = 1x implies simultaneous ...
                           // sample CH0 to CH3
                           // SMPI = 0011 for interrupt after 4 converts

ADCON1bits.ADON = 1;      // turn ADC ON
while (1)                  // repeat continuously
{
    ADC16Ptr = &ADCBUF0;   // initialize ADCBUF pointer
    OutDataPtr = &OutData[0]; // point to first TXbuffer value
    IFS0bits.ADIF = 0;     // clear interrupt
    while (IFS0bits.ADIF); // conversion done?
    for (count = 0; count < 4; count++) // save the ADC values
    {
        ADCValue = *ADC16Ptr++;
        LoadADC(ADCValue);
    }
}                           // repeat
```

17.12.2.3 Multiple Channels with Sequential Sampling

As shown in Figure 17-9 when using sequential sampling, the sample time precedes each conversion time. In the example, 3 TAD clocks are added for sample time for each channel.

Note: This A/D configuration must be enabled for the configuration rates of 1 Msp/s and 600 ksp/s (see Section 17.23 “A/D Conversion Speeds” for further details).

Figure 17-9: Converting 4 Channels, Auto-Sample Start, TAD Conversion Start, Sequential Sampling

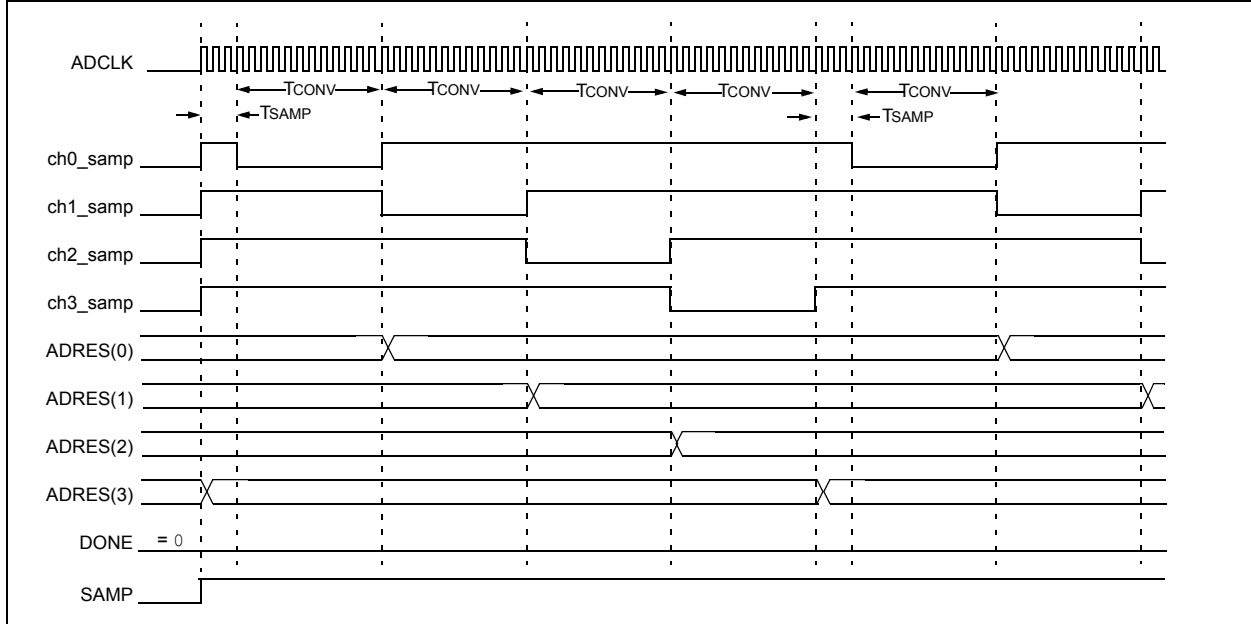

17.12.2.4 Sample Time Considerations Using Clocked Conversion Trigger and Automatic Sampling

Different sample/conversion sequences provide different available sampling times for the S/H channel to acquire the analog signal. The user must ensure the sampling time exceeds the sampling requirements, as outlined in Section 17.17 “A/D Sampling Requirements”.

Assuming that the module is set for automatic sampling and using a clocked conversion trigger, the sampling interval is determined by the sample interval specified by the SAMC bits.

If the SIMSAM bit specifies simultaneous sampling or only one channel is active, the sampling time is the period specified by the SAMC bit.

Equation 17-3: Available Sampling Time, Simultaneous Sampling

$$T_{SMP} = SAMC<4:0> * T_{AD}$$

If the SIMSAM bit specifies sequential sampling, the total interval used to convert all channels is the number of channels times the sampling time and conversion time. The sampling time for an individual channel is the total interval minus the conversion time for that channel.

Equation 17-4: Available Sampling Time, Sequential Sampling

$$T_{SEQ} = \text{Channels per Sample (CH/S)} * ((SAMC<4:0> * T_{AD}) + \text{Conversion Time (TCONV)})$$

$$T_{SMP} = (T_{SEQ} - T_{CONV})$$

Note 1: CH/S specified by CHPS<1:0> bits.
Note 2: TSEQ is the total time for the sample/convert sequence.

17.12.3 Event Trigger Conversion Start

It is often desirable to synchronize the end of sampling and the start of conversion with some other time event. The A/D module may use one of three sources as a conversion trigger.

17.12.3.1 External INT Pin Trigger

When $SSRC\langle 2:0 \rangle = 001$, the A/D conversion is triggered by an active transition on the INT0 pin. The INT0 pin may be programmed for either a rising edge input or a falling edge input.

17.12.3.2 GP Timer Compare Trigger

The A/D is configured in this Trigger mode by setting $SSRC\langle 2:0 \rangle = 010$. When a match occurs between the 32-bit timer TMR3/TMR2 and the 32-bit Combined Period register PR3/PR2, a special ADC trigger event signal is generated by Timer3. This feature does not exist for the TMR5/TMR4 timer pair. Refer to **Section 12. “Timers”** for more details.

17.12.3.3 Motor Control PWM Trigger

The PWM module has an event trigger that allows A/D conversions to be synchronized to the PWM time base. When $SSRC\langle 2:0 \rangle = 011$, the A/D sampling and conversion times occur at any user programmable point within the PWM period. The special event trigger allows the user to minimize the delay between the time when A/D conversion results are acquired and the time when the duty cycle value is updated. Refer to **Section 15. “Motor Control PWM”** for more details.

17.12.3.4 Synchronizing A/D Operations to Internal or External Events

Using the modes where an external event trigger pulse ends sampling and starts conversion ($SSRC = 001, 10, 011$) may be used in combination with auto-sampling ($ASAM = 1$) to cause the A/D to synchronize the sample conversion events to the trigger pulse source. For example, in Figure 17-11 where $SSRC = 010$ and $ASAM = 1$, the A/D will always end sampling and start conversions synchronously with the timer compare trigger event. The A/D will have a sample conversion rate that corresponds to the timer comparison event rate. See Example 17-6 for code example.

Figure 17-10: Converting 1 Channel, Manual Sample Start, Conversion Trigger Based Conversion Start

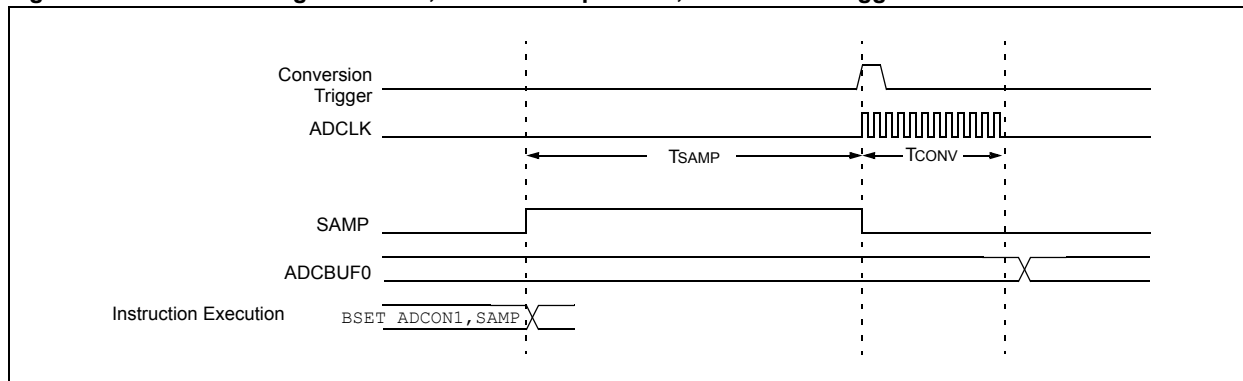
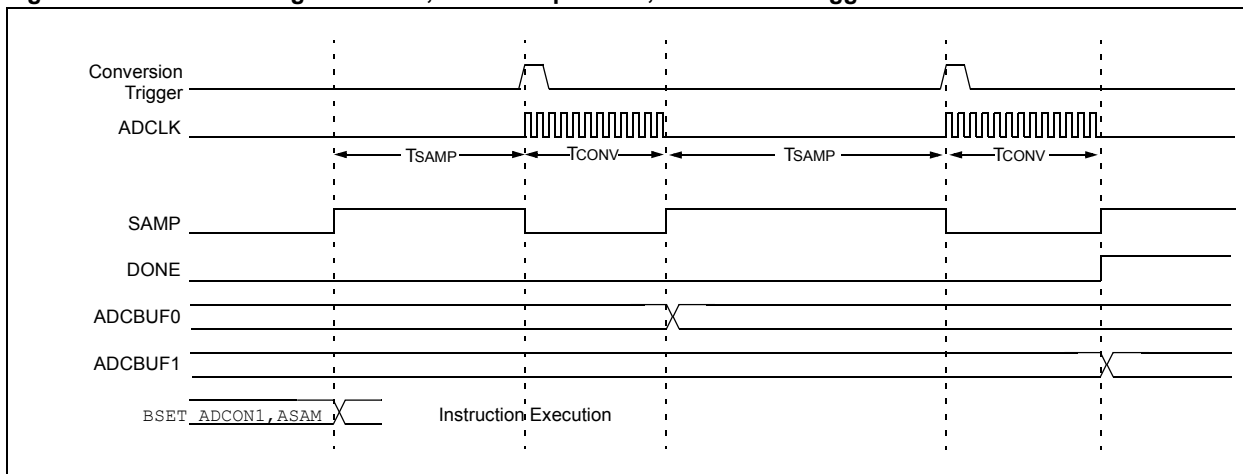

Figure 17-11: Converting 1 Channel, Auto-Sample Start, Conversion Trigger Based Conversion Start



Example 17-6: Converting 1 Channel, Auto-Sample Start, Conversion Trigger Based Conversion Start Code

```

ADPCFG = 0xFFFFB;           // all PORTB = Digital; RB2 analog
ADCON1 = 0x0040;           // SSRC bit = 010 implies GP TMR3
                             // compare ends sampling and starts
                             // converting.
ADCHS  = 0x0002;           // Connect RB2/AN2 as CH0 input ..
                             // in this example RB2/AN2 is the input
ADCSSL = 0;
ADCON3 = 0x0000;           // Sample time is TMR3, Tad = internal Tcy/2
ADCON2 = 0x0004;           // Interrupt after 2 conversions

// set TMR3 to time out every 125 mSecs
TMR3  = 0x0000;
PR3   = 0x3FFF;
T3CON = 0x8010;

ADCON1bits.ADON = 1;       // turn ADC ON
ADCON1bits.ASAM = 1;       // start auto sampling every 125 mSecs
while (1)                  // repeat continuously
{
    while (!IFS0bits.ADIF); // conversion done?
    ADCValue = ADCBUF0;     // yes then get first ADC value
    IFS0bits.ADIF = 0;     // clear ADIF
}
// repeat
    
```

dsPIC30F Family Reference Manual

17.12.3.5 Multiple Channels with Simultaneous Sampling

As shown in Figure 17-12 when using simultaneous sampling, the sampling will start on all channels after setting the ASAM bit or when the last conversion ends. Sampling will stop and conversions will start when the conversion trigger occurs.

Figure 17-12: Converting 4 Channels, Auto-Sample Start, Trigger Conversion Start, Simultaneous Sampling

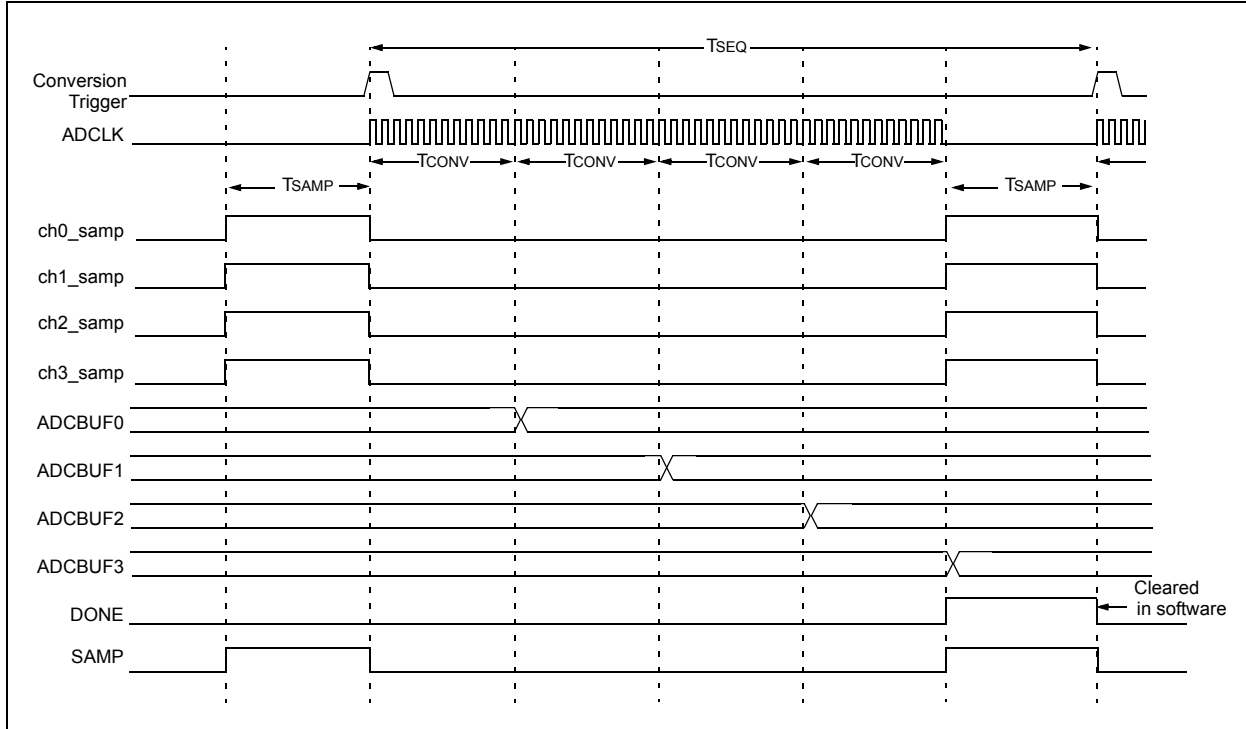

17.12.3.6 Multiple Channels with Sequential Sampling

As shown in Figure 17-13 when using sequential sampling, sampling for a particular channel will stop just prior to converting that channel and will resume after the conversion has stopped.

Figure 17-13: Converting 4 Channels, Auto-Sample Start, Trigger Conversion Start, Sequential Sampling

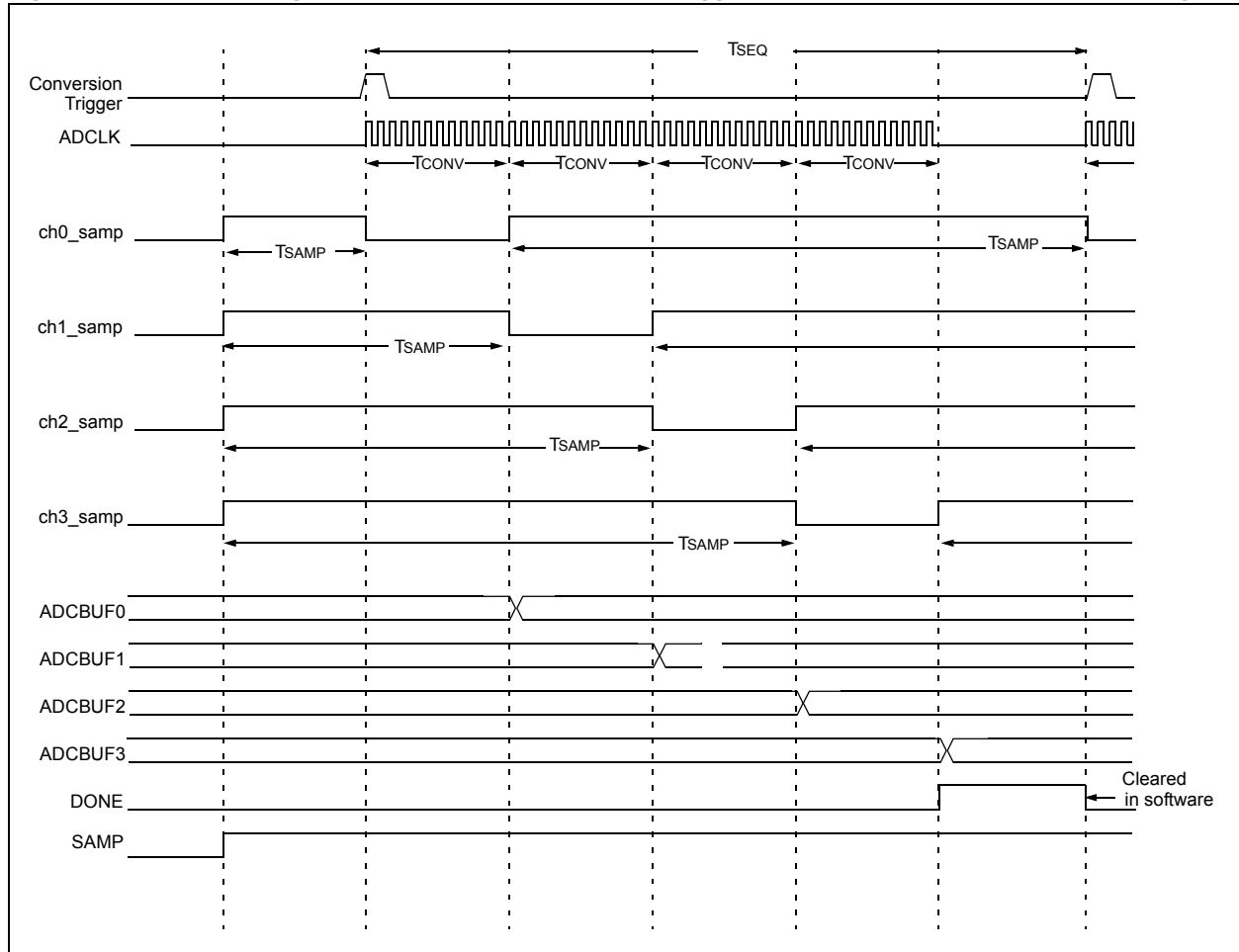

17.12.3.7 Sample Time Considerations for Automatic Sampling/Conversion Sequences

Different sample/conversion sequences provide different available sampling times for the S/H channel to acquire the analog signal. The user must ensure the sampling time exceeds the sampling requirements, as outlined in **Section 17.17 “A/D Sampling Requirements”**.

Assuming that the module is set for automatic sampling and an external trigger pulse is used as the conversion trigger, the sampling interval is a portion of the trigger pulse interval.

If the SIMSAM bit specifies simultaneous sampling, the sampling time is the trigger pulse period less the time required to complete the specified conversions.

Equation 17-5: Available Sampling Time, Simultaneous Sampling

$$\begin{aligned} T_{SMP} &= \text{Trigger Pulse Interval (TSEQ)} - \\ &\quad \text{Channels per Sample (CH/S)} * \text{Conversion Time (TCONV)} \\ T_{SMP} &= TSEQ - (CH/S * TCONV) \end{aligned}$$

- Note 1:** CH/S specified by CHPS<1:0> bits.
Note 2: TSEQ is the trigger pulse interval time.

If the SIMSAM bit specifies sequential sampling, the sampling time is the trigger pulse period less the time required to complete only one conversion.

Equation 17-6: Available Sampling Time, Sequential Sampling

$$\begin{aligned} T_{SMP} &= \text{Trigger Pulse Interval (TSEQ)} - \\ &\quad \text{Conversion Time (TCONV)} \\ T_{SMP} &= TSEQ - TCONV \end{aligned}$$

- Note:** TSEQ is the trigger pulse interval time.

17.13 Controlling Sample/Conversion Operation

The application software may poll the SAMP and DONE bits to keep track of the A/D operations or the module can interrupt the CPU when conversions are complete. The application software may also abort A/D operations if necessary.

17.13.1 Monitoring Sample/Conversion Status

The SAMP (ADCON1<1>) and DONE (ADCON1<0>) bits indicate the sampling state and the conversion state of the A/D, respectively. Generally, when the SAMP bit clears, indicating end of sampling, the DONE bit is automatically set, indicating end of conversion. If both SAMP and DONE are '0', the A/D is in an inactive state. In some Operational modes, the SAMP bit may also invoke and terminate sampling.

17.13.2 Generating an A/D Interrupt

The SMPI<3:0> bits control the generation of interrupts. The interrupt will occur some number of sample/conversion sequences after starting sampling and re-occur on each equivalent number of samples. Note that the interrupts are specified in terms of samples and not in terms of conversions or data samples in the buffer memory.

When the SIMSAM bit specifies sequential sampling, regardless of the number of channels specified by the CHPS bits, the module samples once for each conversion and data sample in the buffer. Therefore, the value specified by the SMPI bits will correspond to the number of data samples in the buffer, up to the maximum of 16.

When the SIMSAM bit specifies simultaneous sampling, the number of data samples in the buffer is related to the CHPS bits. Algorithmically, the channels/sample times the number of samples will result in the number of data sample entries in the buffer. To avoid loss of data in the buffer due to overruns, the SMPI bits must be set to the desired buffer size divided by the channels per sample.

Disabling the A/D interrupt is not done with the SMPI bits. To disable the interrupt, clear the ADIE analog module interrupt enable bit.

17.13.3 Aborting Sampling

Clearing the SAMP bit while in Manual Sampling mode will terminate sampling, but may also start a conversion if SSRC = 000.

Clearing the ASAM bit while in Automatic Sampling mode will not terminate an on going sample/convert sequence, however, sampling will not automatically resume after subsequent conversions.

17.13.4 Aborting a Conversion

Clearing the ADON bit during a conversion will abort the current conversion. The A/D Result register pair will NOT be updated with the partially completed A/D conversion sample. That is, the corresponding ADCBUF buffer location will continue to contain the value of the last completed conversion (or the last value written to the buffer).

17.14 Specifying How Conversion Results are Written Into the Buffer

As conversions are completed, the module writes the results of the conversions into the A/D result buffer. This buffer is a RAM array of sixteen 10-bit words. The buffer is accessed through 16 address locations within the SFR space named ADCBUF0...ADCBUFF.

User software may attempt to read each A/D conversion result as it is generated, however, this would consume too much CPU time. Generally, to simplify the code, the module will fill the buffer with results and then generate an interrupt when the buffer is filled.

17.14.1 Number of Conversions per Interrupt

The SMPI<3:0> bits (ADCON2<5:2>) will select how many A/D conversions will take place before the CPU is interrupted. This can vary from 1 sample per interrupt to 16 samples per interrupt. The A/D converter module always starts writing its conversion results at the beginning of the buffer, after each interrupt. For example, if SMPI<3:0> = 0000, the conversion results will always be written to ADCBUF0. In this example, no other buffer locations would be used.

17.14.2 Restrictions Due to Buffer Size

The user cannot program a combination of CHPS and SMPI bits that specifies more than 16 conversions per interrupt when the BUFM bit (ADCON2<1>) is '0', or 8 conversions per interrupt when the BUFM bit (ADCON2<1>) is '0'. The BUFM bit function is described below.

17.14.3 Buffer Fill Mode

When the BUFM bit (ADCON2<1>) is '1', the 16-word results buffer (ADRES) will be split into two 8-word groups. The 8-word buffers will alternately receive the conversion results after each interrupt event. The initial 8-word buffer used after BUFM is set will be located at the lower addresses of ADCBUF. When BUFM is '0', the complete 16-word buffer is used for all conversion sequences.

The decision to use the BUFM feature will depend upon how much time is available to move the buffer contents after the interrupt, as determined by the application. If the processor can quickly unload a full buffer within the time it takes to sample and convert one channel, the BUFM bit can be '0' and up to 16 conversions may be done per interrupt. The processor will have one sample and conversion time before the first buffer location is overwritten.

If the processor cannot unload the buffer within the sample and conversion time, the BUFM bit should be '1'. For example, if SMPI<3:0> = 0111, then eight conversions will be loaded into 1/2 of the buffer, following which an interrupt will occur. The next eight conversions will be loaded into the other 1/2 of the buffer. The processor will therefore have the entire time between interrupts to move the eight conversions out of the buffer.

17.14.4 Buffer Fill Status

When the conversion result buffer is split using the BUFM control bit, the BUFS status bit (ADCON2<7>) indicates the half of the buffer that the A/D converter is currently filling. If BUFS = 0, then the A/D converter is filling ADCBUF0-ADCBUF7 and the user software should read conversion values from ADCBUF8-ADCBUFF. If BUFS = 1, the situation is reversed and the user software should read conversion values from ADCBUF0-ADCBUF7.

17.15 Turning the A/D Module Off

The following sequence is recommended for turning the A/D module off:

1. Clear the ADON bit (ADCON1<15>).
2. Set the ADCMD bit (PMD1<0>).
3. Wait 2 instructions.
4. Clear the ADCMD bit (PMD1<0>).
5. Reinitialize the ADC module (optional).

The ADCMD bit is the peripheral module disable bit. Setting this bit prevents the A/D module from receiving a clock. Setting and then clearing this bit resets the A/D module.

17.16 Conversion Sequence Examples

The following configuration examples show the A/D operation in different sampling and buffering configurations. In each example, setting the ASAM bit starts automatic sampling. A conversion trigger ends sampling and starts conversion.

17.16.1 Example: Sampling and Converting a Single Channel Multiple Times

Figure 17-11 and Table 17-2 illustrate a basic configuration of the A/D. In this case, one A/D input, AN0, will be sampled by one sample and hold channel, CH0, and converted. The results are stored in the ADCBUF buffer. This process repeats 16 times until the buffer is full and then the module generates an interrupt. The entire process will then repeat.

The CHPS bits specify that only sample/hold CH0 is active. With ALTS clear, only the MUX A inputs are active. The CH0SA bits and CH0NA bit are specified (AN0-VREF-) as the input to the sample/hold channel. All other input selection bits are not used.

Figure 17-14: Converting One Channel 16 Times/Interrupt

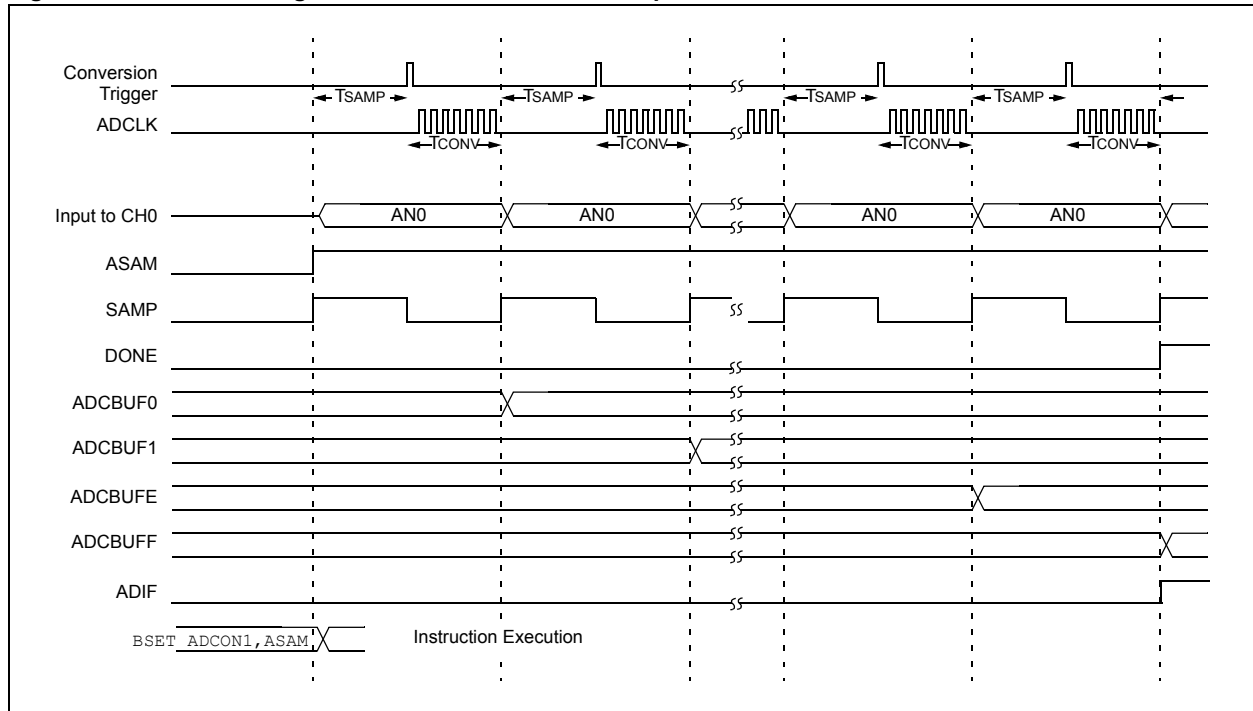

dsPIC30F Family Reference Manual

Table 17-2: Converting One Channel 16 Times/Interrupt

CONTROL BITS	
Sequence Select	
SMPI<2:0> = 1111	Interrupt on 16th sample
CHPS<1:0> = 00	Sample Channel CH0
SIMSAM = n/a	Not applicable for single channel sample
BUFM = 0	Single 16-word result buffer
ALTS = 0	Always use MUX A input select
MUX A Input Select	
CH0SA<3:0> = 0000	Select AN0 for CH0+ input
CH0NA = 0	Select VREF- for CH0- input
CSCNA = 0	No input scan
CSSL<15:0> = n/a	Scan input select unused
CH123SA = n/a	Channel CH1, CH2, CH3+ input unused
CH123NA<1:0> = n/a	Channel CH1, CH2, CH3- input unused
MUX B Input Select	
CH0SB<3:0> = n/a	Channel CH0+ input unused
CH0NB = n/a	Channel CH0- input unused
CH123SB = n/a	Channel CH1, CH2, CH3+ input unused
CH123NB<1:0> = n/a	Channel CH1, CH2, CH3- input unused

OPERATION SEQUENCE
Sample MUX A Inputs: AN0 -> CH0
Convert CH0, Write Buffer 0x0
Sample MUX A Inputs: AN0 -> CH0
Convert CH0, Write Buffer 0x1
Sample MUX A Inputs: AN0 -> CH0
Convert CH0, Write Buffer 0x2
Sample MUX A Inputs: AN0 -> CH0
Convert CH0, Write Buffer 0x3
Sample MUX A Inputs: AN0 -> CH0
Convert CH0, Write Buffer 0x4
Sample MUX A Inputs: AN0 -> CH0
Convert CH0, Write Buffer 0x5
Sample MUX A Inputs: AN0 -> CH0
Convert CH0, Write Buffer 0x6
Sample MUX A Inputs: AN0 -> CH0
Convert CH0, Write Buffer 0x7
Sample MUX A Inputs: AN0 -> CH0
Convert CH0, Write Buffer 0x8
Sample MUX A Inputs: AN0 -> CH0
Convert CH0, Write Buffer 0x9
Sample MUX A Inputs: AN0 -> CH0
Convert CH0, Write Buffer 0xA
Sample MUX A Inputs: AN0 -> CH0
Convert CH0, Write Buffer 0xB
Sample MUX A Inputs: AN0 -> CH0
Convert CH0, Write Buffer 0xC
Sample MUX A Inputs: AN0 -> CH0
Convert CH0, Write Buffer 0xD
Sample MUX A Inputs: AN0 -> CH0
Convert CH0, Write Buffer 0xE
Sample MUX A Inputs: AN0 -> CH0
Convert CH0, Write Buffer 0xF
Interrupt
Repeat

Buffer Address

ADCBUF0
ADCBUF1
ADCBUF2
ADCBUF3
ADCBUF4
ADCBUF5
ADCBUF6
ADCBUF7
ADCBUF8
ADCBUF9
ADCBUFA
ADCBUFB
ADCBUFC
ADCBUFD
ADCBUFE
ADCBUFF

Buffer @ 1st Interrupt

AN0 sample 1
AN0 sample 2
AN0 sample 3
AN0 sample 4
AN0 sample 5
AN0 sample 6
AN0 sample 7
AN0 sample 8
AN0 sample 9
AN0 sample 10
AN0 sample 11
AN0 sample 12
AN0 sample 13
AN0 sample 14
AN0 sample 15
AN0 sample 16

Buffer @ 2nd Interrupt

AN0 sample 17
AN0 sample 18
AN0 sample 19
AN0 sample 20
AN0 sample 21
AN0 sample 22
AN0 sample 23
AN0 sample 24
AN0 sample 25
AN0 sample 26
AN0 sample 27
AN0 sample 28
AN0 sample 29
AN0 sample 30
AN0 sample 31
AN0 sample 32

• • •

17.16.2 Example: A/D Conversions While Scanning Through All Analog Inputs

Figure 17-15 and Table 17-3 illustrate a very typical setup where all available analog input channels are sampled by one sample and hold channel, CH0, and converted. The set CSCNA bit specifies scanning of the A/D inputs to the CH0 positive input. Other conditions are similar to Subsection 17.16.1.

Initially, the AN0 input is sampled by CH0 and converted. The result is stored in the ADCBUF buffer. Then the AN1 input is sampled and converted. This process of scanning the inputs repeats 16 times until the buffer is full and then the module generates an interrupt. The entire process will then repeat.

Figure 17-15: Scanning Through 16 Inputs/Interrupt

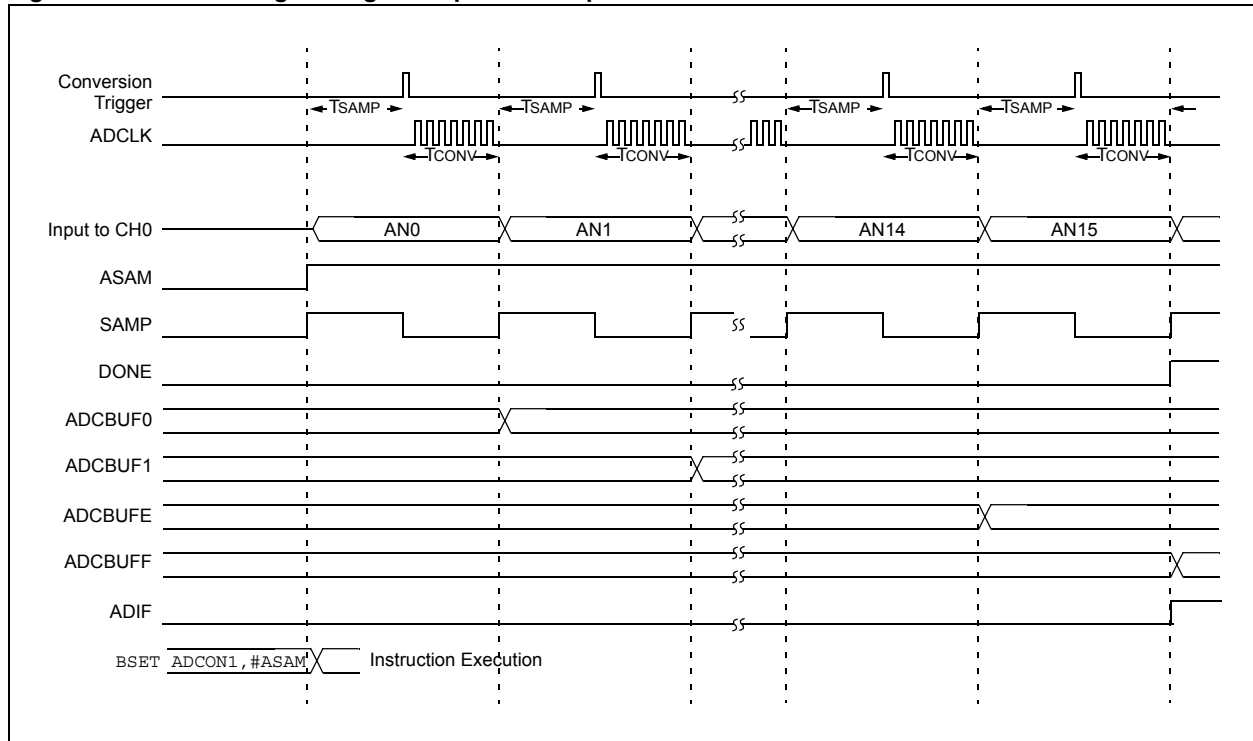

dsPIC30F Family Reference Manual

Table 17-3: Scanning Through 16 Inputs/Interrupt

CONTROL BITS Sequence Select	OPERATION SEQUENCE
SMPI<2:0> = 1111 Interrupt on 16th sample	Sample MUX A Inputs: AN0 -> CH0 Convert CH0, Write Buffer 0x0
CHPS<1:0> = 00 Sample Channel CH0	Sample MUX A Inputs: AN1 -> CH0 Convert CH0, Write Buffer 0x1
SIMSAM = n/a Not applicable for single channel sample	Sample MUX A Inputs: AN2 -> CH0 Convert CH0, Write Buffer 0x2
BUFM = 0 Single 16-word result buffer	Sample MUX A Inputs: AN3 -> CH0 Convert CH0, Write Buffer 0x3
ALTS = 0 Always use MUX A input select	Sample MUX A Inputs: AN4 -> CH0 Convert CH0, Write Buffer 0x4
MUX A Input Select	
CH0SA<3:0> = n/a Override by CSCNA	Sample MUX A Inputs: AN5 -> CH0 Convert CH0, Write Buffer 0x5
CH0NA = 0 Select VREF- for CH0- input	Sample MUX A Inputs: AN6 -> CH0 Convert CH0, Write Buffer 0x6
CSCNA = 1 Scan CH0+ Inputs	Sample MUX A Inputs: AN7 -> CH0 Convert CH0, Write Buffer 0x7
CSSL<15:0> = 1111 1111 1111 1111 Scan input select unused	Sample MUX A Inputs: AN8 -> CH0 Convert CH0, Write Buffer 0x8
CH123SA = n/a Channel CH1, CH2, CH3+ input unused	Sample MUX A Inputs: AN9 -> CH0 Convert CH0, Write Buffer 0x9
CH123NA<1:0> = n/a Channel CH1, CH2, CH3- input unused	Sample MUX A Inputs: AN10 -> CH0 Convert CH0, Write Buffer 0xA
MUX B Input Select	
CH0SB<3:0> = n/a Channel CH0+ input unused	Sample MUX A Inputs: AN11 -> CH0 Convert CH0, Write Buffer 0xB
CH0NB = n/a Channel CH0- input unused	Sample MUX A Inputs: AN12 -> CH0 Convert CH0, Write Buffer 0xC
CH123SB = n/a Channel CH1, CH2, CH3+ input unused	Sample MUX A Inputs: AN13 -> CH0 Convert CH0, Write Buffer 0xD
CH123NB<1:0> = n/a Channel CH1, CH2, CH3- input unused	Sample MUX A Inputs: AN14 -> CH0 Convert CH0, Write Buffer 0xE
	Sample MUX A Inputs: AN15 -> CH0 Convert CH0, Write Buffer 0xF
	Interrupt
	Repeat

Buffer Address

ADCBUF0
ADCBUF1
ADCBUF2
ADCBUF3
ADCBUF4
ADCBUF5
ADCBUF6
ADCBUF7
ADCBUF8
ADCBUF9
ADCBUFA
ADCBUFB
ADCBUFC
ADCBUFD
ADCBUFE
ADCBUFF

Buffer @ 1st Interrupt

AN0 sample 1
AN1 sample 2
AN2 sample 3
AN3 sample 4
AN4 sample 5
AN5 sample 6
AN6 sample 7
AN7 sample 8
AN8 sample 9
AN9 sample 10
AN10 sample 11
AN11 sample 12
AN12 sample 13
AN13 sample 14
AN14 sample 15
AN15 sample 16

Buffer @ 2nd Interrupt

AN0 sample 17
AN1 sample 18
AN2 sample 19
AN3 sample 20
AN4 sample 21
AN5 sample 22
AN6 sample 23
AN7 sample 24
AN8 sample 25
AN9 sample 26
AN10 sample 27
AN11 sample 28
AN12 sample 29
AN13 sample 30
AN14 sample 31
AN15 sample 32

• • •

17.16.3 Example: Sampling Three Inputs Frequently While Scanning Four Other Inputs

Figure 17-16 and Table 17-4 shows how the A/D converter could be configured to sample three inputs frequently using sample/hold channels CH1, CH2 and CH3; while four other inputs are sampled less frequently by scanning them using sample/hold channel CH0. In this case, only MUX A inputs are used, and all 4 channels are sampled simultaneously. Four different inputs (AN4, AN5, AN6, AN7) are scanned in CH0, whereas AN0, AN1 and AN2 are the fixed inputs for CH1, CH2 and CH3, respectively. Thus, in every set of 16 samples, AN0, AN1 and AN2 would be sampled 4 times, while AN4, AN5, AN6 and AN7 would be sampled only once each.

Figure 17-16: Converting Three Inputs, Four Times and Four Inputs, One Time/Interrupt

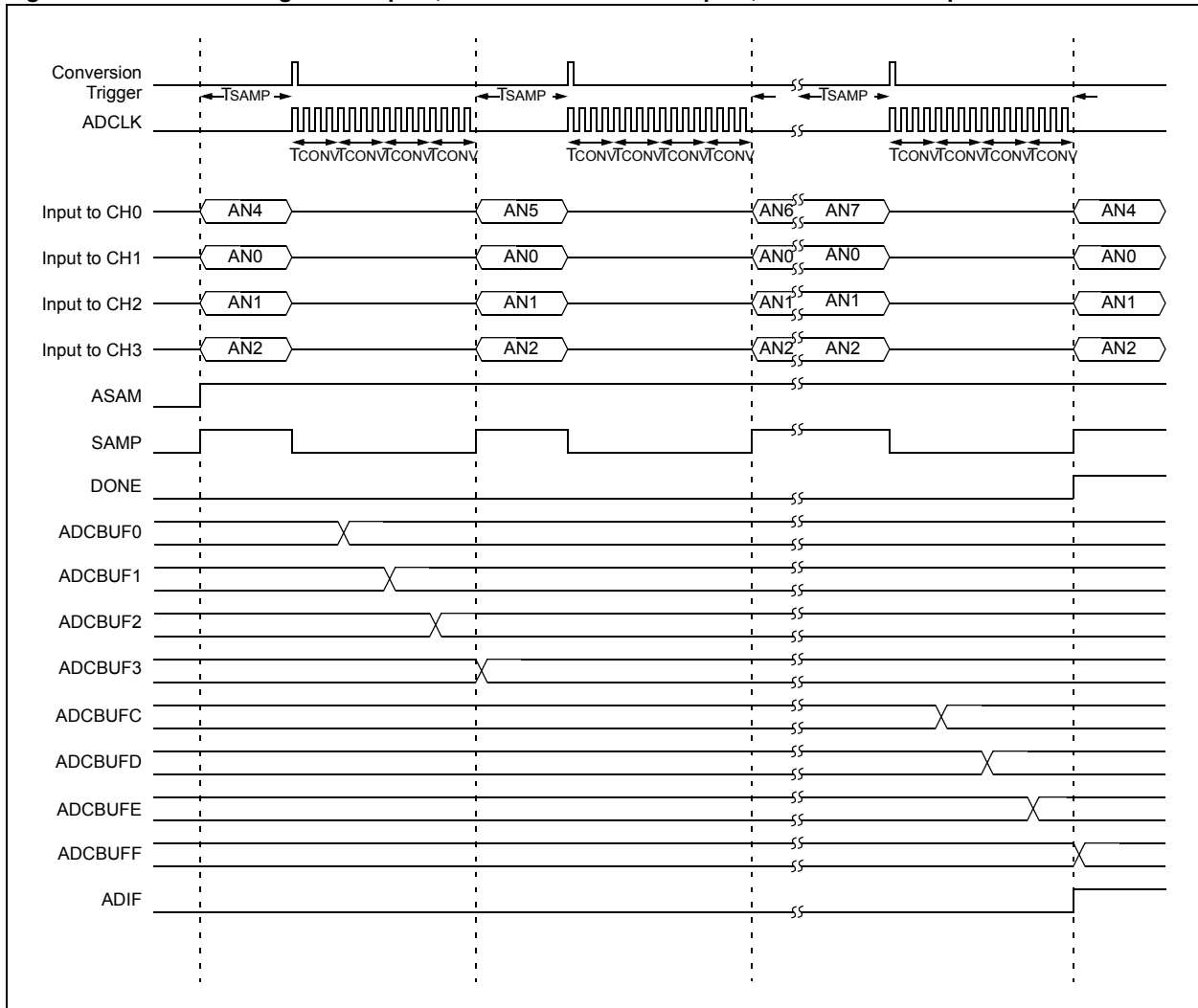

17.16.4 Example: Using Dual 8-Word Buffers

Figure 17-17 and Table 17-5 demonstrate using dual 8-word buffers and alternating the buffer fill. Setting the BUFM bit enables dual 8-word buffers. The BUFM setting does not affect other operational parameters. First, the conversion sequence starts filling the buffer at ADCBUF0 (buffer location 0x0). After the first interrupt occurs, the buffer begins to fill at ADCBUF8 (buffer location 0x8). The BUFS status bit is set and cleared alternately after each interrupt. In this example, all four channels are sampled simultaneously, and an interrupt occurs after every sample.

Figure 17-17: Converting Four Inputs, One Time/Interrupt Using Dual 8-Word Buffers

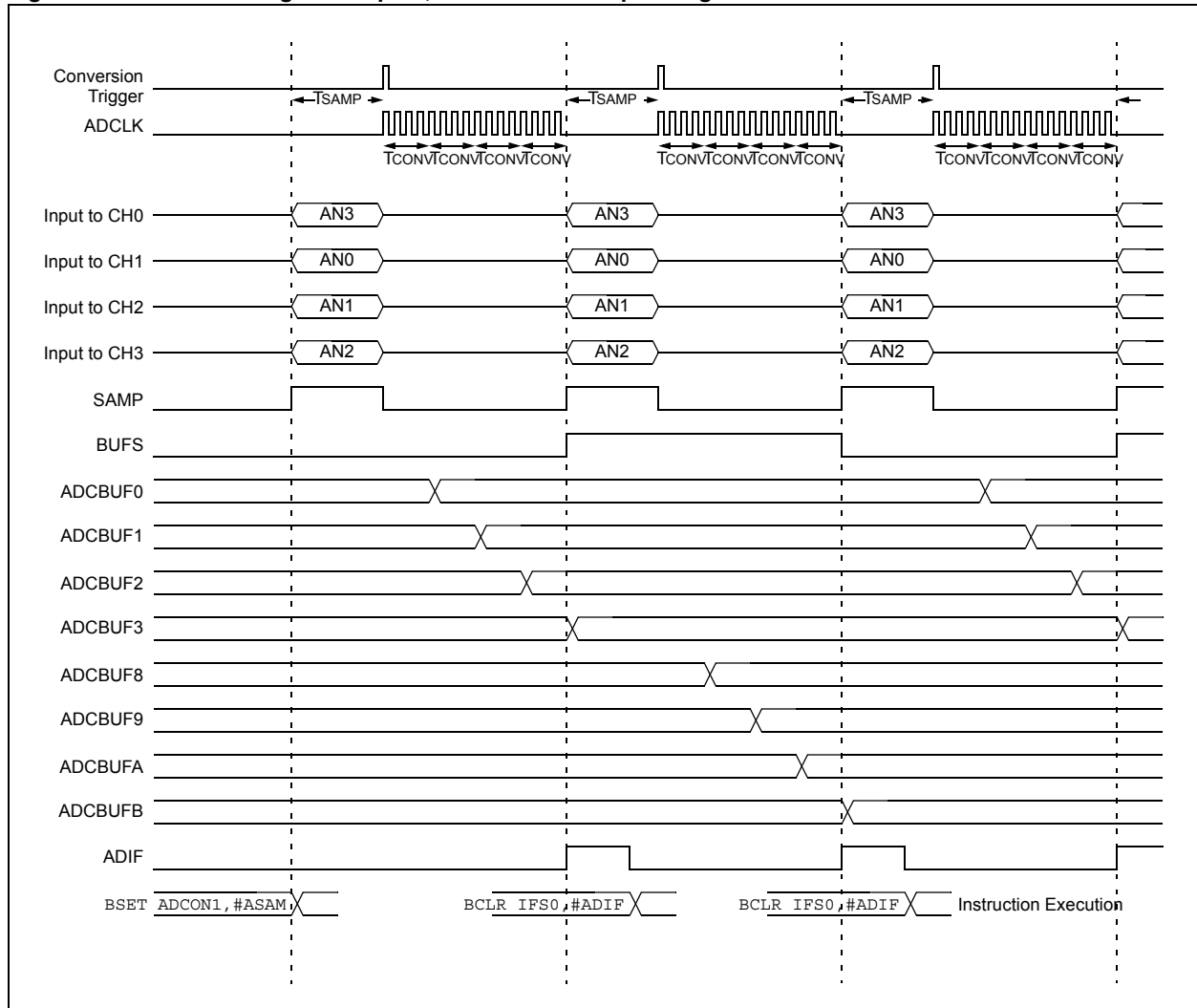

dsPIC30F Family Reference Manual

Table 17-5: Converting Four Inputs, One Time/Interrupt Using Dual 8-Word Buffers

CONTROL BITS Sequence Select	OPERATION SEQUENCE
SMPI<2:0> = 0000 Interrupt on each sample	Sample MUX A Inputs: AN3 -> CH0, AN0 -> CH1, AN1 -> CH2, AN2 -> CH3
CHPS<1:0> = 1x Sample Channels CH1, CH2, CH3, CH0	Convert CH0, Write Buffer 0x0
SIMSAM = 1 Sample all channels simultaneously	Convert CH1, Write Buffer 0x1
BUFM = 1 Dual 8-word result buffers	Convert CH2, Write Buffer 0x2
ALTS = 0 Always use MUX A input select	Convert CH3, Write Buffer 0x3
MUX A Input Select	Interrupt; Change Buffer
CH0SA<3:0> = 0011 Select AN3 for CH0+ input	Sample MUX A Inputs: AN3 -> CH0, AN0 -> CH1, AN1 -> CH2, AN2 -> CH3
CH0NA = 0 Select VREF- for CH0- input	Convert CH0, Write Buffer 0x8
CSCNA = 0 No input scan	Convert CH1, Write Buffer 0x9
CSSL<15:0> = n/a Scan input select unused	Convert CH2, Write Buffer 0xA
CH123SA = 0 CH1+ = AN0, CH2+ = AN1, CH3+ = AN2	Convert CH3, Write Buffer 0xB
CH123NA<1:0> = 0x CH1-, CH2-, CH3- = VREF-	Interrupt; Change Buffer
MUX B Input Select	Repeat
CH0SB<3:0> = n/a Channel CH0+ input unused	
CH0NB = n/a Channel CH0- input unused	
CH123SB = n/a Channel CH1, CH2, CH3+ input unused	
CH123NB<1:0> = n/a Channel CH1, CH2, CH3- input unused	

Buffer Address	Buffer @ 1st Interrupt	Buffer @ 2nd Interrupt
ADCBUF0	AN3 sample 1	
ADCBUF1	AN0 sample 1	
ADCBUF2	AN1 sample 1	
ADCBUF3	AN2 sample 1	
ADCBUF4		
ADCBUF5		
ADCBUF6		
ADCBUF7		
ADCBUF8		AN3 sample 2
ADCBUF9		AN0 sample 2
ADCBUFA		AN1 sample 2
ADCBUFB		AN2 sample 2
ADCBUFC		
ADCBUFD		
ADCBUFE		
ADCBUFF		

• • •

17.16.5 Example: Using Alternating MUX A, MUX B Input Selections

Figure 17-18 and Table 17-6 demonstrate alternate sampling of the inputs assigned to MUX A and MUX B. In this example, 2 channels are enabled to sample simultaneously. Setting the ALTS bit enables alternating input selections. The first sample uses the MUX A inputs specified by the CH0SA, CH0NA, CHXSA and CHXNA bits. The next sample uses the MUX B inputs specified by the CH0SB, CH0NB, CHXSB and CHXNB bits. In this example, one of the MUX B input specifications uses 2 analog inputs as a differential source to the sample/hold, sampling (AN3-AN9).

This example also demonstrates use of the dual 8-word buffers. An interrupt occurs after every 4th sample, resulting in filling 8-words into the buffer on each interrupt.

Note that using 4 sample/hold channels without alternating input selections results in the same number of conversions as this example, using 2 channels with alternating input selections. However, because the CH1, CH2 and CH3 channels are more limited in the selectivity of the analog inputs, this example method provides more flexibility of input selection than using 4 channels.

Figure 17-18: Converting Two Sets of Two Inputs Using Alternating Input Selections

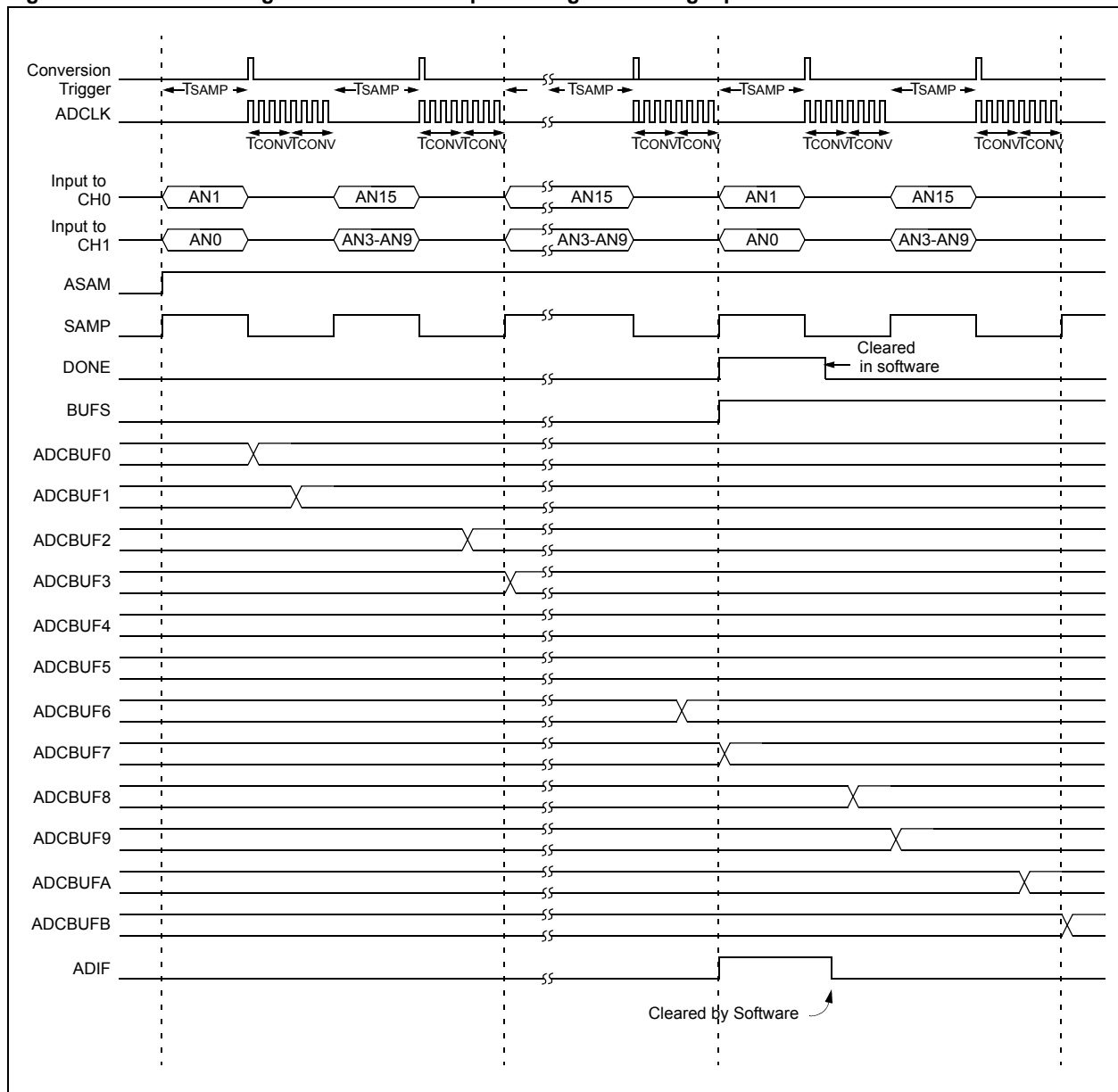

dsPIC30F Family Reference Manual

Table 17-7: Sampling Eight Inputs Using Simultaneous Sampling

CONTROL BITS Sequence Select	OPERATION SEQUENCE
SMPI<2:0> = 0011 Interrupt on 4th sample	Sample MUX A Inputs: (AN13-AN1) -> CH0, AN0 -> CH1, AN1 -> CH2, AN2 -> CH3
CHPS<1:0> = 1x Sample Channels CH0, CH1, CH2, CH3	Convert CH0, Write Buffer 0x0
SIMSAM = 1 Sample all channels simultaneously	Convert CH1, Write Buffer 0x1
BUFM = 0 Single 16-word result buffer	Convert CH2, Write Buffer 0x2
ALTS = 1 Alternate MUX A/MUX B input select	Convert CH3, Write Buffer 0x3
MUX A Input Select	Sample MUX B Inputs: AN14 -> CH0, (AN3-AN6) -> CH1, (AN4-AN7) -> CH2, (AN5-AN8) -> CH3
CH0SA<3:0> = 1101 Select AN13 for CH0+ input	Convert CH0, Write Buffer 0x4
CH0NA = 1 Select AN1 for CH0- input	Convert CH1, Write Buffer 0x5
CSCNA = 0 No input scan	Convert CH2, Write Buffer 0x6
CSSL<15:0> = n/a Scan input select unused	Convert CH3, Write Buffer 0x7
CH123SA = 0 CH1+ = AN0, CH2+ = AN1, CH3+ = AN2	Sample MUX A Inputs: (AN13-AN1) -> CH0, AN0 -> CH1, AN1 -> CH2, AN2 -> CH3
CH123NA<1:0> = 0x CH1-, CH2-, CH3- = VREF-	Convert CH0, Write Buffer 0x8
MUX B Input Select	Convert CH1, Write Buffer 0x9
CH0SB<3:0> = 1110 Select AN14 for CH0+ input	Convert CH2, Write Buffer 0xA
CH0NB = 0 Select VREF- for CH0- input	Convert CH3, Write Buffer 0xB
CH123SB = 1 CH1+ = AN3, CH2+ = AN4, CH3+ = AN5	Sample MUX B Inputs: AN14 -> CH0, (AN3-AN6) -> CH1, (AN4-AN7) -> CH2, (AN5-AN8) -> CH3
CH123NB<1:0> = 10 CH1- = AN6, CH2- = AN7, CH3- = AN8	Convert CH0, Write Buffer 0xC
	Convert CH1, Write Buffer 0xD
	Convert CH2, Write Buffer 0xE
	Convert CH3, Write Buffer 0xF
	Interrupt
	Repeat

Buffer Address

Buffer @ 1st Interrupt

Buffer @ 2nd Interrupt

ADCBUF0	(AN13-AN1) sample 1	(AN13-AN1) sample 5
ADCBUF1	AN0 sample 1	AN0 sample 5
ADCBUF2	AN1 sample 1	AN1 sample 5
ADCBUF3	AN2 sample 1	AN2 sample 5
ADCBUF4	AN14 sample 2	AN14 sample 6
ADCBUF5	(AN3-AN6) sample 2	(AN3-AN6) sample 6
ADCBUF6	(AN4-AN7) sample 2	(AN4-AN7) sample 6
ADCBUF7	(AN5-AN8) sample 2	(AN5-AN8) sample 6
ADCBUF8	(AN13-AN1) sample 3	(AN13-AN1) sample 7
ADCBUF9	AN0 sample 3	AN0 sample 7
ADCBUFA	AN1 sample 3	AN1 sample 7
ADCBUFB	AN2 sample 3	AN2 sample 7
ADCBUFC	AN14 sample 4	AN14 sample 8
ADCBUFD	(AN3-AN6) sample 4	(AN3-AN6) sample 8
ADCBUFE	(AN4-AN7) sample 4	(AN4-AN7) sample 8
ADCBUFF	(AN5-AN8) sample 4	(AN5-AN8) sample 8

• • •

17.16.7 Example: Sampling Eight Inputs Using Sequential Sampling

Figure 17-20 and Table 17-8 demonstrate sequential sampling. When converting more than one channel and selecting sequential sampling, the module will start sampling a channel at the earliest opportunity, then perform the required conversions in sequence. In this example, with ASAM set, sampling of a channel will begin after the conversion of that channel completes.

When ASAM is clear, sampling will not resume after conversion completion but will occur when setting the SAMP bit.

When utilizing more than one channel, sequential sampling provides more sampling time since a channel may be sampled while conversion occurs on another.

Figure 17-20: Sampling Eight Inputs Using Sequential Sampling

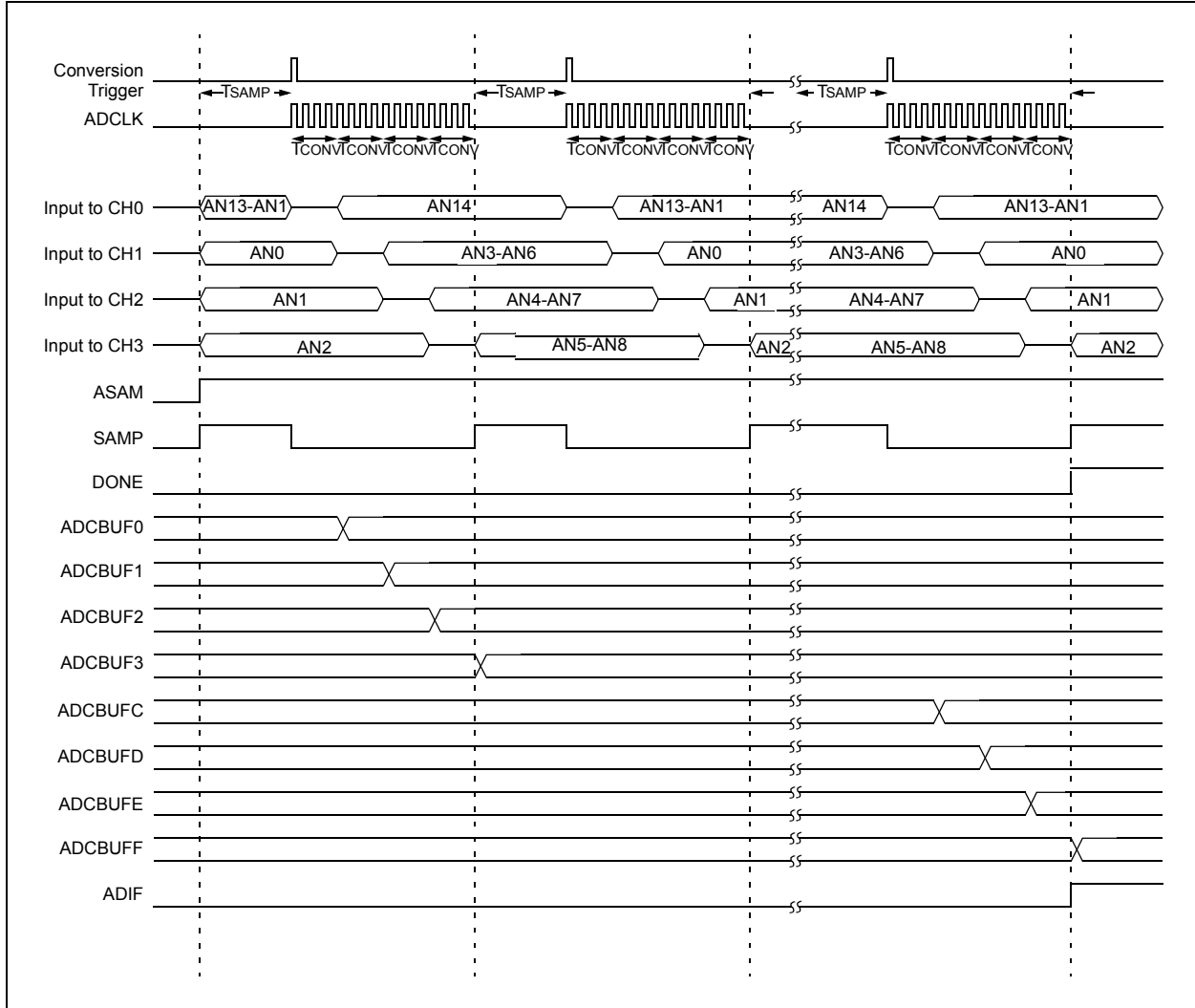

dsPIC30F Family Reference Manual

Table 17-8: Sampling Eight Inputs Using Sequential Sampling

CONTROL BITS Sequence Select	OPERATION SEQUENCE
SMPI<2:0> = 1111 Interrupt on 16th sample	Sample: (AN13-AN1) -> CH0 Convert CH0, Write Buffer 0x0
CHPS<1:0> = 1x Sample Channels CH0, CH1, CH2, CH3	Sample: AN0 -> CH1 Convert CH1, Write Buffer 0x1
SIMSAM = 0 Sample all channels sequentially	Sample: AN1 -> CH2 Convert CH2, Write Buffer 0x2
BUFM = 0 Single 16-word result buffer	Sample: AN2 -> CH3 Convert CH3, Write Buffer 0x3
ALTS = 1 Alternate MUX A/B input select	Sample: AN14 -> CH0 Convert CH0, Write Buffer 0x4
MUX A Input Select	
CHOSA<3:0> = 0110 Select AN6 for CH0+ input	Sample: (AN3-AN6) -> CH1 Convert CH1, Write Buffer 0x5
CH0NA = 0 Select VREF- for CH0- input	Sample: (AN4-AN7) -> CH2 Convert CH2, Write Buffer 0x6
CSCNA = 0 No input scan	Sample: (AN5-AN8) -> CH3 Convert CH3, Write Buffer 0x7
CSSL<15:0> = n/a Scan input select unused	Sample: (AN13-AN1) -> CH0 Convert CH0, Write Buffer 0x8
CH123SA = 0 CH1+ = AN0, CH2+ = AN1, CH3+ = AN2	Sample: AN0 -> CH1 Convert CH1, Write Buffer 0x9
CH123NA<1:0> = 0x CH1-, CH2-, CH3- = VREF-	Sample: AN1 -> CH2 Convert CH2, Write Buffer 0xA
MUX B Input Select	
CHOSB<3:0> = 0111 Select AN7 for CH0+ input	Sample: AN2 -> CH3 Convert CH3, Write Buffer 0xB
CH0NB = 0 Select VREF- for CH0- input	Sample: AN14 -> CH0 Convert CH0, Write Buffer 0xC
CH123SB = 1 CH1+ = AN3, CH2+ = AN4, CH3+ = AN5	Sample: (AN3-AN6) -> CH1 Convert CH1, Write Buffer 0xD
CH123NB<1:0> = 0x CH1-, CH2-, CH3- = VREF-	Sample: (AN4-AN7) -> CH2 Convert CH2, Write Buffer 0xE
	Sample: (AN5-AN8) -> CH3 Convert CH3, Write Buffer 0xF
	Interrupt
	Repeat

Buffer Address

ADCBUF0
ADCBUF1
ADCBUF2
ADCBUF3
ADCBUF4
ADCBUF5
ADCBUF6
ADCBUF7
ADCBUF8
ADCBUF9
ADCBUFA
ADCBUFB
ADCBUFC
ADCBUFD
ADCBUFE
ADCBUFF

**Buffer @
1st Interrupt**

(AN13-AN1) sample 1
AN0 sample 2
AN1 sample 3
AN2 sample 4
AN14 sample 5
(AN3-AN6) sample 6
(AN4-AN7) sample 7
(AN5-AN8) sample 8
(AN13-AN1) sample 9
AN0 sample 10
AN1 sample 11
AN2 sample 12
AN14 sample 13
(AN3-AN6) sample 14
(AN4-AN7) sample 15
(AN5-AN8) sample 16

**Buffer @
2nd Interrupt**

(AN13-AN1) sample 17
AN0 sample 18
AN1 sample 19
AN2 sample 20
AN14 sample 21
(AN3-AN6) sample 22
(AN4-AN7) sample 23
(AN5-AN8) sample 24
(AN13-AN1) sample 25
AN0 sample 26
AN1 sample 27
AN2 sample 28
AN14 sample 29
(AN3-AN6) sample 30
(AN4-AN7) sample 31
(AN5-AN8) sample 32

• • •

17.17 A/D Sampling Requirements

The analog input model of the 10-bit A/D converter is shown in Figure 17-21. The total sampling time for the A/D is a function of the internal amplifier settling time and the holding capacitor charge time.

For the A/D converter to meet its specified accuracy, the charge holding capacitor (CHOLD) must be allowed to fully charge to the voltage level on the analog input pin. The analog output source impedance (RS), the interconnect impedance (RIC), and the internal sampling switch (RSS) impedance combine to directly affect the time required to charge the capacitor CHOLD. The combined impedance must therefore be small enough to fully charge the holding capacitor within the chosen sample time. To minimize the effects of pin leakage currents on the accuracy of the A/D converter, the maximum recommended source impedance, RS, is 5 kΩ for the conversion rates of up to 500 ksp/s and a maximum of 500Ω for conversion rates of up to 1 Msp/s. After the analog input channel is selected (changed), this sampling function must be completed prior to starting the conversion. The internal holding capacitor will be in a discharged state prior to each sample operation.

At least 1 TAD time period should be allowed between conversions for the sample time. For more details, see the device electrical specifications.

Figure 17-21: 10-bit A/D Converter Analog Input Model

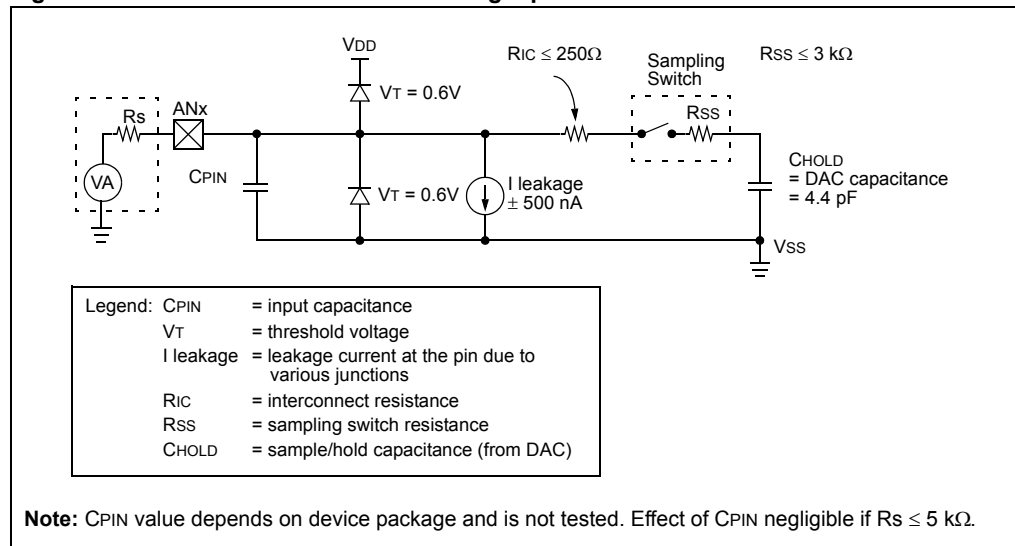

dsPIC30F Family Reference Manual

17.18 Reading the A/D Result Buffer

The RAM is 10 bits wide, but the data is automatically formatted to one of four selectable formats when a read from the buffer is performed. The FORM<1:0> bits (ADCON1<9:8>) select the format. The formatting hardware provides a 16-bit result on the data bus for all of the data formats. Figure 17-22 shows the data output formats that can be selected using the FORM<1:0> control bits.

Figure 17-22: A/D Output Data Formats

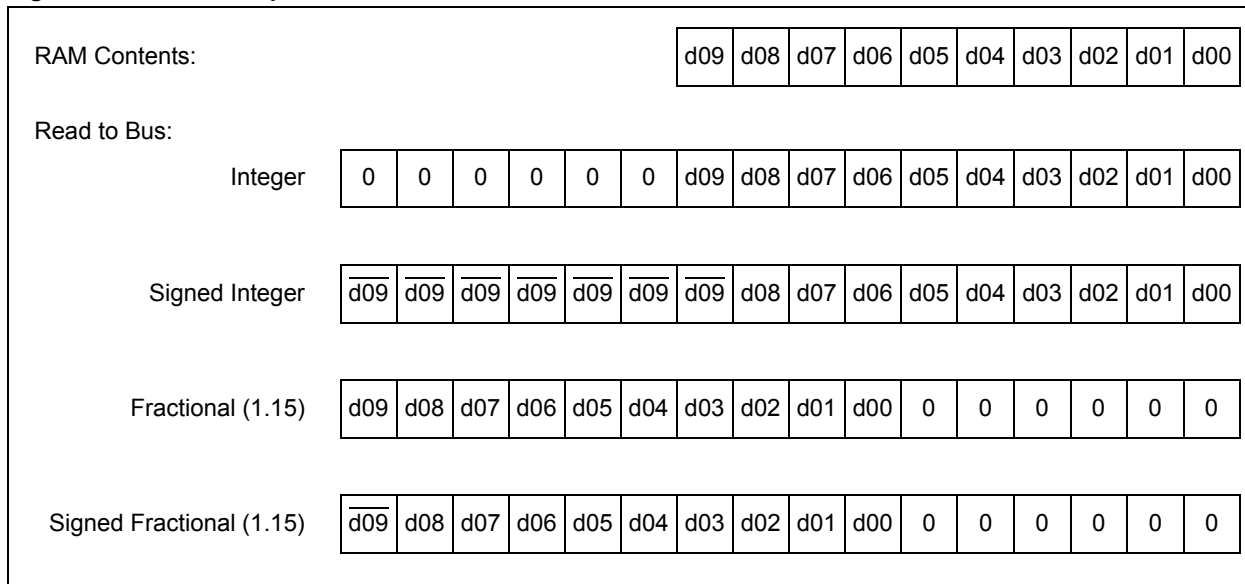

Figure 17-23: Numerical Equivalents of Various Result Codes

V _{IN} /V _{REF}	10-bit Output Code	16-bit Integer Format	16-bit Signed Integer Format	16-bit Fractional Format	16-bit Signed Fractional Format
1023/1024	11 1111 1111	0000 0011 1111 1111 = 1023	0000 0001 1111 1111 = 511	1111 1111 1100 0000 = 0.999	0111 1111 1100 0000 = 0.499
1022/1024	11 1111 1110	0000 0011 1111 1110 = 1022	0000 0001 1111 1110 = 510	1111 1111 1000 0000 = 0.998	0111 1111 1000 0000 = 0.498
...					
513/1024	10 0000 0001	0000 0010 0000 0001 = 513	0000 0000 0000 0001 = 1	1000 0000 0100 0000 = 0.501	0 000 0000 0100 0000 = 0.001
512/1024	10 0000 0000	0000 0010 0000 0000 = 512	0000 0000 0000 0000 = 0	1000 0000 0000 0000 = 0.500	0000 0000 0000 0000 = 0.000
511/1024	01 1111 1111	0000 0001 1111 1111 = 511	1111 1111 1111 1111 = -1	0111 1111 1100 0000 = .499	1111 1111 1100 0000 = -0.001
...					
1/1024	00 0000 0001	0000 0000 0000 0001 = 1	1111 1110 0000 0001 = -511	0000 0000 0100 0000 = 0.001	1000 0000 0100 0000 = -0.499
0/1024	00 0000 0000	0000 0000 0000 0000 = 0	1111 1110 0000 0000 = -512	0000 0000 0000 0000 = 0.000	1000 0000 0000 0000 = -0.500

17.19 Transfer Function

The ideal transfer function of the A/D converter is shown in Figure 17-24. The difference of the input voltages, ($V_{INH} - V_{INL}$), is compared to the reference, ($V_{REFH} - V_{REFL}$).

- The first code transition occurs when the input voltage is ($V_{REFH} - V_{REFL}/2048$) or 0.5 LSB.
- The 00 0000 0001 code is centered at ($V_{REFH} - V_{REFL}/1024$) or 1.0 LSB.
- The 10 0000 0000 code is centered at ($512 * (V_{REFH} - V_{REFL})/1024$).
- An input voltage less than ($1 * (V_{REFH} - V_{REFL})/2048$) converts as 00 0000 0000.
- An input greater than ($2045 * (V_{REFH} - V_{REFL})/2048$) converts as 11 1111 1111.

Figure 17-24: A/D Transfer Function

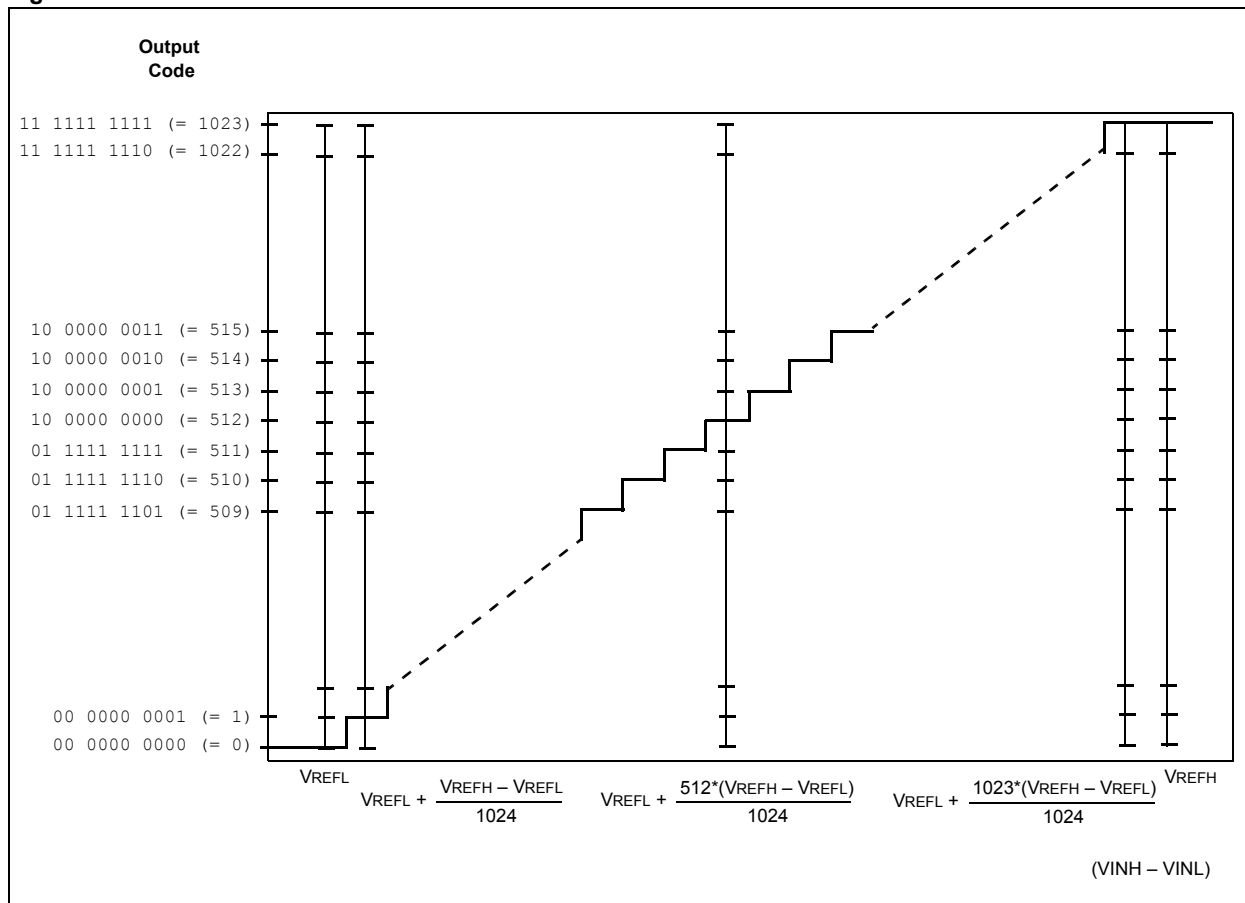

17.20 A/D Accuracy/Error

Refer to **Section 17.28 “Related Application Notes”** for a list of documents that discuss A/D accuracy.

17.21 Connection Considerations

Since the analog inputs employ ESD protection, they have diodes to V_{DD} and V_{SS} . This requires that the analog input must be between V_{DD} and V_{SS} . If the input voltage exceeds this range by greater than 0.3V (either direction), one of the diodes becomes forward biased and it may damage the device if the input current specification is exceeded.

An external RC filter is sometimes added for anti-aliasing of the input signal. The R component should be selected to ensure that the sampling time requirements are satisfied. Any external components connected (via high-impedance) to an analog input pin (capacitor, zener diode, etc.) should have very little leakage current at the pin.

17.22 Initialization

Example 17-7 shows a simple initialization code example for the A/D module.

In this particular configuration, all 16 analog input pins, AN0-AN15, are set up as analog inputs. Operation in Idle mode is disabled output data is in unsigned fractional format, and AVDD and AVSS are used for VREFH and VREFL. The start of sampling, as well as start of conversion (conversion trigger), are performed manually in software. The CH0 S/H amplifier is used for conversions. Scanning of inputs is disabled, and an interrupt occurs after every sample/convert sequence (1 conversion result). The A/D conversion clock is Tcy/2.

Since sampling is started manually by setting the SAMP bit (ADCON1<1>) after each conversion is complete, the auto-sample time bits, SAMC<4:0> (ADCON3<12:8>), are ignored. Moreover, since the start of conversion (i.e., end of sampling) is also triggered manually, the SAMP bit needs to be cleared each time a new sample needs to be converted.

Example 17-7: A/D Initialization Code Example

```
CLR      ADPCFG          ; Configure A/D port,
                        ; all input pins are analog

MOV      #0x2208,W0
MOV      W0,ADCON1      ; Configure sample clock source
                        ; and conversion trigger mode.
                        ; Unsigned Fractional format,
                        ; Manual conversion trigger,
                        ; Manual start of sampling,
                        ; Simultaneous sampling,
                        ; No operation in IDLE mode.

CLR      ADCON2          ; Configure A/D voltage reference
                        ; and buffer fill modes.
                        ; VREF from AVDD and AVSS,
                        ; Inputs are not scanned,
                        ; 1 S/H channel used,
                        ; Interrupt every sample

CLR      ADCON3          ; Configure A/D conversion clock

CLR      ADCHS           ; Configure input channels,
                        ; CH0+ input is AN0.
                        ; CH0- input is VREFL (AVss)

CLR      ADCSSL          ; No inputs are scanned.

BCLR     IFS0,#ADIF      ; Clear A/D conversion interrupt

; Configure A/D interrupt priority bits (ADIP<2:0>) here, if
; required. (default priority level is 4)

BSET     IEC0,#ADIE      ; Enable A/D conversion interrupt

BSET     ADCON1,#ADON     ; Turn on A/D
BSET     ADCON1,#SAMP     ; Start sampling the input
CALL     DELAY            ; Ensure the correct sampling time has
                        ; elapsed before starting conversion.

BCLR     ADCON1,#SAMP     ; End A/D Sampling and start Conversion
:
:                         ; The DONE bit is set by hardware when
:                         ; the convert sequence is finished
:                         ; The ADIF bit will be set.
```

17.23 A/D Conversion Speeds

The dsPIC30F 10-bit A/D converter specifications permit a maximum 1 Msps sampling rate. The table below summarizes the conversion speeds for the dsPIC30F 10-bit A/D converter and the required operating conditions.

Table 17-9: 10-bit Conversion Rate Parameters

dsPIC30F 10-bit A/D Converter Conversion Rates						
A/D Speed	TAD Minimum	Sampling Time Min	R _s Max	VDD	Temperature	A/D Channels Configuration
Up to 1 Msps ⁽¹⁾	83.33 ns	12 TAD	500 Ω	4.5V to 5.5V	-40°C to +85°C	
Up to 750 ksps ⁽¹⁾	95.24 ns	2 TAD	500 Ω	4.5V to 5.5V	-40°C to +85°C	
Up to 600 ksps ⁽¹⁾	138.89 ns	12 TAD	500 Ω	3.0V to 5.5V	-40°C to +125°C	
Up to 500 ksps	153.85 ns	1 TAD	5.0 kΩ	4.5V to 5.5V	-40°C to +125°C	
Up to 300 ksps	256.41 ns	1 TAD	5.0 kΩ	3.0V to 5.5V	-40°C to +125°C	

Note 1: External VREF- and VREF+ pins must be used for correct operation. See Figure 17-25 for recommended circuit.

dsPIC30F Family Reference Manual

The following figure depicts the recommended circuit for the conversion rates above 500 ksp/s. The dsPIC30F6010 is shown as an example.

Figure 17-25: A/D Converter Voltage Reference Schematic

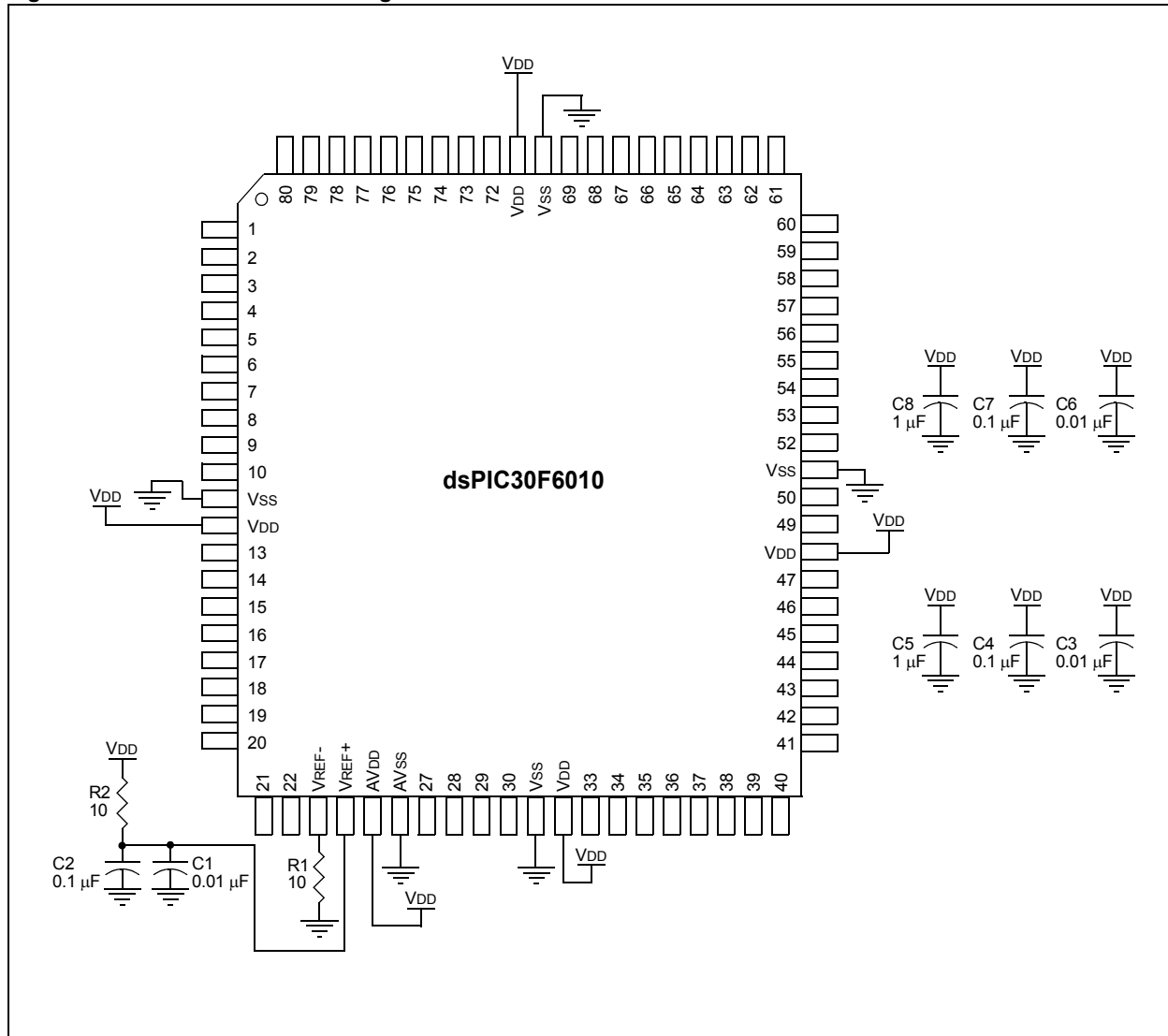

The configuration procedures below give the required setup values for the conversion speeds above 500 ksp/s.

17.23.1 1 Msp/s Configuration Guideline

The configuration for 1 Msp/s operation is dependent on whether a single input pin is to be sampled or whether multiple pins will be sampled.

17.23.1.1 Single Analog Input

For conversions at 1 Msp/s for a single analog input, at least two sample and hold channels must be enabled. The analog input multiplexer must be configured so that the same input pin is connected to both sample and hold channels. The A/D converts the value held on one S/H channel, while the second S/H channel acquires a new input sample.

17.23.1.2 Multiple Analog Inputs

The A/D converter can also be used to sample multiple analog inputs using multiple sample and hold channels. In this case, the total 1 Msp/s conversion rate is divided among the different input signals. For example, four inputs can be sampled at a rate of 250 ksp/s for each signal or two inputs could be sampled at a rate of 500 ksp/s for each signal. Sequential sampling must be used in this configuration to allow adequate sampling time on each input.

17.23.1.3 1 Msp/s Configuration Procedure

The following configuration items are required to achieve a 1 Msp/s conversion rate.

- Comply with conditions provided in Table 17-9.
- Connect external VREF+ and VREF- pins following the recommended circuit shown in Figure 17-26.
- Set SSRC<2:0> = 111 in the ADCON1 register to enable the auto-convert option.
- Enable automatic sampling by setting the ASAM control bit in the ADCON1 register.
- Enable sequential sampling by clearing the SIMSAM bit in the ADCON1 register.
- Enable at least two sample and hold channels by writing the CHPS<1:0> control bits in the ADCON2 register.
- Configure at least 2 conversions between interrupts, since at least two sample and hold channels, by writing the SMPI<3:0> control bits in the ADCON2 register.
- Configure the A/D clock period to be:

$$\frac{1}{12 \times 1,000,000} = 83.33 \text{ ns}$$

by writing to the ADCS<5:0> control bits in the ADCON3 register.

- Configure the sampling time to be 12 TAD by writing: SAMC<4:0> = 01100.
- Select at least two channels per analog input pin by writing to the ADCHS register.

The following figure shows the timing diagram of the A/D converting one input pin using two sample and holds. The TAD selection, in conjunction with the guidelines described above, allows a conversion speed of 1 Msp/s. See Example 17-8 for code example.

Figure 17-26: Converting 1 Input Pin Using Two Channels at 1 Msp/s, Auto-Sample Start, 12 TAD Sampling Time

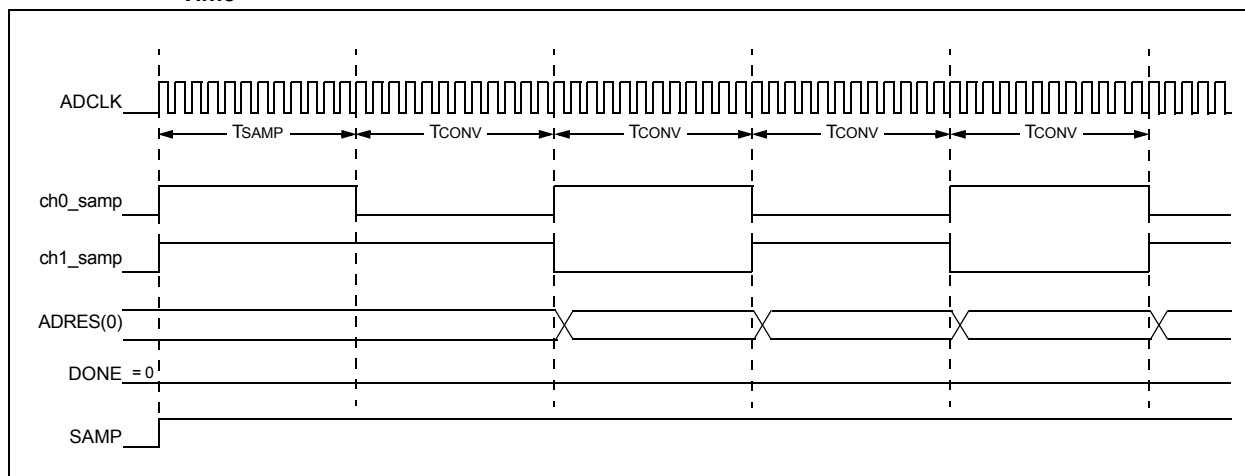

Example 17-8: Converting 2 Channels, Auto-Sample Start, TAD Conversion Start, Sequential Sampling Code

```
ADPCFG = 0xFFFF; // all PORTB = Digital; RB2 = analog
ADCON1 = 0x00E0; // SSRC bit = 111 implies internal
// counter ends sampling and starts
// converting.
ADCHS = 0x0002; // Connect RB2/AN2 as CH0 input and also connect
RB2/AN2
// to positive CH1 input.
// in this example RB2/AN2 is the input to two
channels.
ADCSSL = 0;
ADCON3 = 0x0C04; // Sample time = 12Tad = 83.33 ns @ MIPS
// which will give 1 / (12 * 83.33 ns) = 1 Msps
ADCON2 = 0x6104; // Select external VREF+ and VREF- pins, convert CH0
and
// CH1, Interrupt after every 2 samples
ADCON1bits.ADON = 1; // turn ADC ON
while (1) // repeat continuously
{
    IFS0bits.ADIF = 0; // clear interrupt
    while (IFS0bits.ADIF); // conversion done?
    ADCValue = ADCBUF0; // save the ADC values
} // repeat
```

17.23.2 750 ksp Configuration Guideline

The following configuration items are required to achieve a 750 ksp conversion rate. This configuration assumes that a single analog input is to be sampled.

- Comply with conditions provided in Table 17-9.
- Connect external VREF+ and VREF- pins following the recommended circuit shown in Figure 17-27.
- Set SSRC<2:0> = 111 in the ADCON1 register to enable the auto-convert option.
- Enable automatic sampling by setting the ASAM control bit in the ADCON1 register.
- Enable one sample and hold channel by setting CHPS<1:0> = 00 in the ADCON2 register.
- Write the SMP1<3:0> control bits in the ADCON2 register for the desired number of conversions between interrupts.
- Configure the A/D clock period to be:

$$\frac{1}{(12 + 2) \times 750,000} = 95.24 \text{ ns}$$

by writing to the ADCS<5:0> control bits in the ADCON3 register.

- Configure the sampling time to be 2 TAD by writing: SAMC<4:0> = 00010.

The following figure shows the timing diagram of the A/D running at 750 ksp. The TAD selection, in conjunction with the guidelines described above, allows a conversion speed of 750 ksp. See Example 17-9 for code example.

Figure 17-27: Converting 1 Channel at 750 ksps, Auto-Sample Start, 2 TAD Sampling Time

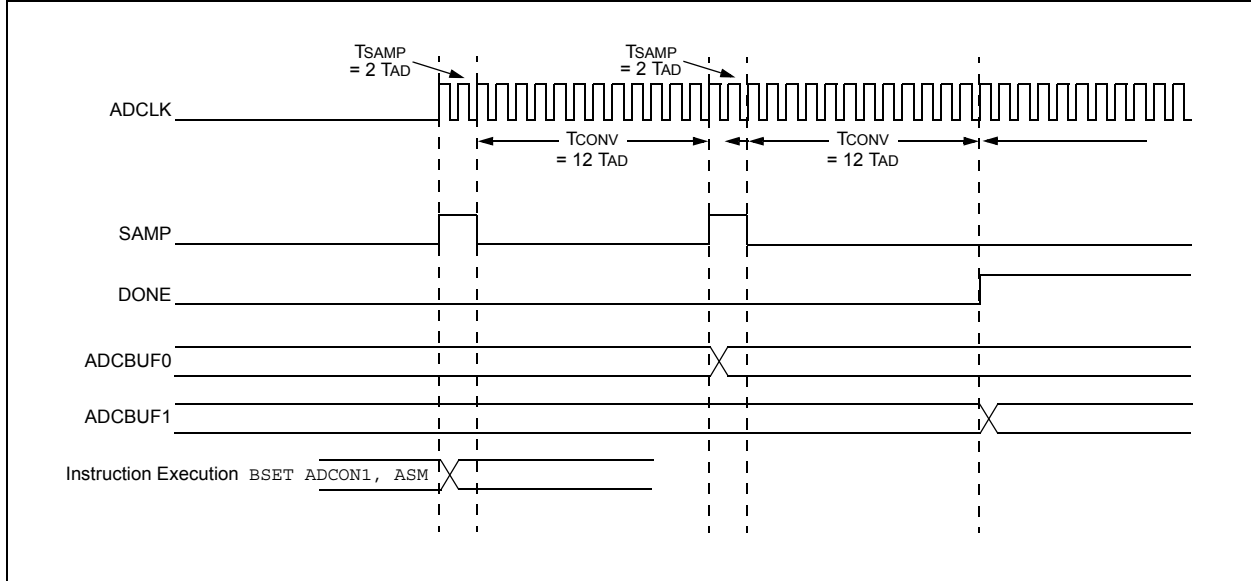

Example 17-9: Converting 1 Channel at 750 ksps, Auto-Sample Start, 2 TAD Sampling Time Code Example

```

ADPCFG = 0xFFFB; // all PORTB = Digital; RB2 = analog
ADCON1 = 0x00E0; // SSRC bit = 111 implies internal
                // counter ends sampling and starts
                // converting.
ADCHS  = 0x0002; // Connect RB2/AN2 as CH0 input
                // in this example RB2/AN2 is the input
ADCSSL = 0;
ADCON3 = 0x0203; // Sample time = 2Tad, Tad = 95.24 ns @ 21 MIPS
                // which will give 1 / (14 * 95.24 ns) = 750 ksps
ADCON2 = 0x6004; // Select external VREF+ and VREF- pins
                // Interrupt after every 2 samples
ADCON1bits.ADON = 1; // turn ADC ON
while (1) // repeat continuously
{
    ADCValue = 0; // clear value
    ADC16Ptr = &ADCBUF0; // initialize ADCBUF pointer
    IFS0bits.ADIF = 0; // clear ADC interrupt flag
    ADCON1bits.ASAM = 1; // auto start sampling
                    // for 31Tad then go to conversion
    while (!IFS0bits.ADIF); // conversion done?
    ADCON1bits.ASAM = 0; // yes then stop sample/convert
    for (count = 0; count <2; count++) // average the 2 ADC value
        ADCValue = ADCValue + *ADC16Ptr++;
    ADCValue = ADCValue >> 1;
}
                // repeat
    
```

17.23.3 600 ksps Configuration Guideline

The configuration for 600 ksps operation is dependent on whether a single input pin is to be sampled or whether multiple pins will be sampled.

17.23.3.1 Single Analog Input

When performing conversions at 600 ksps for a single analog input, at least two sample and hold channels must be enabled. The analog input multiplexer must be configured so that the same input pin is connected to both sample and hold channels. The A/D converts the value held on one S/H channel, while the second S/H channel acquires a new input sample.

17.23.3.2 Multiple Analog Inputs

The A/D converter can also be used to sample multiple analog inputs using multiple sample and hold channels. In this case, the total 600 ksp/s conversion rate is divided among the different input signals. For example, four inputs can be sampled at a rate of 150 ksp/s for each signal or two inputs could be sampled at a rate of 300 ksp/s for each signal. Sequential sampling must be used in this configuration to allow adequate sampling time on each input.

17.23.3.3 600 ksp/s Configuration Items

The following configuration items are required to achieve a 600 ksp/s conversion rate.

- Comply with conditions provided in Table 17-9.
- Connect external VREF+ and VREF- pins following the recommended circuit shown in Figure 17-10.
- Set SSRC<2:0> = 111 in the ADCON1 register to enable the auto-convert option.
- Enable automatic sampling by setting the ASAM control bit in the ADCON1 register.
- Enable sequential sampling by clearing the SIMSAM bit in the ADCON1 register.
- Enable at least two sample and hold channels by writing the CHPS<1:0> control bits in the ADCON2 register.
- Configure at least 2 conversions between interrupts, since at least two sample and hold channels, by writing the SMPI<3:0> control bits in the ADCON2 register.
- Configure the A/D clock period to be:

$$\frac{1}{12 \times 600,000} = 138.89 \text{ ns}$$

by writing to the ADCS<5:0> control bits in the ADCON3 register.

- Configure the sampling time to be 2 TAD by writing: SAMC<4:0> = 00010.
- Select at least two channels per analog input pin by writing to the ADCHS register.

The timing diagram for the 600 ksp/s extended rate is the same as for the 1 Msp/s shown in Figure 17-10. See Example 17-10 for code example for 600 ksp/s A/D operation.

Example 17-10: Converting 2 Channels, Auto-Sample Start, TAD Conversion Start, Sequential Sampling Code

```
ADPCFG = 0xFFFB;    // all PORTB = Digital; RB2 = analog
ADCON1 = 0x00E0;    // SSRC bit = 111 implies internal
                    // counter ends sampling and starts
                    // converting.
ADCHS   = 0x0002;    // Connect RB2/AN2 as CH0 input and also connect
RB2/AN2                                // to positive CH1 input.
                                        // in this example RB2/AN2 is the input to two
channels.
ADCSSL  = 0;
ADCON3 = 0x0C04;    // Sample time = 12Tad = 138.89 ns @ 18 MIPS
                    // which will give 1 / (12 * 138.89 ns) = 600 ksp/s
ADCON2 = 0x6104;    // Select external VREF+ and VREF- pins, convert CH0
and                                     // CH1, Interrupt after every 2 samples
ADCON1bits.ADON = 1; // turn ADC ON
while (1)           // repeat continuously
{
    IFS0bits.ADIF = 0; // clear interrupt
    while (IFS0bits.ADIF); // conversion done?
    ADCValue = ADCBUF0; // save the ADC values
}
                    // repeat
```

17.24 Operation During Sleep and Idle Modes

Sleep and Idle modes are useful for minimizing conversion noise because the digital activity of the CPU, buses and other peripherals is minimized.

17.24.1 CPU Sleep Mode without RC A/D Clock

When the device enters Sleep mode, all clock sources to the module are shutdown and stay at logic '0'.

If Sleep occurs in the middle of a conversion, the conversion is aborted unless the A/D is clocked from its internal RC clock generator. The converter will not resume a partially completed conversion on exiting from Sleep mode.

Register contents are not affected by the device entering or leaving Sleep mode.

17.24.2 CPU Sleep Mode with RC A/D Clock

The A/D module can operate during Sleep mode if the A/D clock source is set to the internal A/D RC oscillator ($ADRC = 1$). This eliminates digital switching noise from the conversion. When the conversion is completed, the DONE bit will be set and the result loaded into the A/D result buffer, ADCBUF.

If the A/D interrupt is enabled ($ADIE = 1$), the device will wake-up from Sleep when the A/D interrupt occurs. Program execution will resume at the A/D Interrupt Service Routine (ISR) if the A/D interrupt is greater than the current CPU priority. Otherwise, execution will continue from the instruction after the `PWRSVAV` instruction that placed the device in Sleep mode.

If the A/D interrupt is not enabled, the A/D module will then be turned off, although the ADON bit will remain set.

To minimize the effects of digital noise on the A/D module operation, the user should select a conversion trigger source that ensures the A/D conversion will take place in Sleep mode. The automatic conversion trigger option can be used for sampling and conversion in Sleep ($SSRC<2:0> = 111$). To use the automatic conversion option, the ADON bit should be set in the instruction prior to the `PWRSVAV` instruction.

Note: For the A/D module to operate in Sleep, the A/D clock source must be set to RC ($ADRC = 1$).

17.24.3 A/D Operation During CPU Idle Mode

For the A/D, the ADSIDL bit ($ADCON1<13>$) selects if the module will stop on Idle or continue on Idle. If $ADSIDL = 0$, the module will continue normal operation when the device enters Idle mode. If the A/D interrupt is enabled ($ADIE = 1$), the device will wake up from Idle mode when the A/D interrupt occurs. Program execution will resume at the A/D Interrupt Service Routine if the A/D interrupt is greater than the current CPU priority. Otherwise, execution will continue from the instruction after the `PWRSVAV` instruction that placed the device in Idle mode.

If $ADSIDL = 1$, the module will stop in Idle. If the device enters Idle mode in the middle of a conversion, the conversion is aborted. The converter will not resume a partially completed conversion on exiting from Idle mode.

17.25 Effects of a Reset

A device Reset forces all registers to their Reset state. This forces the A/D module to be turned off, and any conversion in progress is aborted. All pins that are multiplexed with analog inputs will be configured as analog inputs. The corresponding TRIS bits will be set.

The values in the ADCBUF registers are not initialized during a Power-on Reset. ADCBUF0...ADCBUFF will contain unknown data.

17.26 Special Function Registers Associated with the 10-bit A/D Converter

The following table lists dsPIC30F 10-bit A/D Converter Special Function registers, including their addresses and formats. All unimplemented registers and/or bits within a register read as zeros.

Table 17-10: ADC Register Map

File Name	ADR	Bit 15	Bit 14	Bit 13	Bit 12	Bit 11	Bit 10	Bit 9	Bit 8	Bit 7	Bit 6	Bit 5	Bit 4	Bit 3	Bit 2	Bit 1	Bit 0	Reset States
INTCON1	0080	NSTDIS	—	—	—	—	OVATE	OVATE	COVTE	—	—	—	MATHERR	ADDRERR	STKERR	OSCFAIL	—	0000 0000 0000 0000
INTCON2	0082	ALTIPT	—	—	—	—	—	—	—	—	—	—	INT4EP	INT3EP	INT2EP	INT1EP	INT0EP	0000 0000 0000 0000
IFS0	0084	CNIF	MI2CIF	SI2CIF	NVMIF	ADIF	U1TXIF	U1RXIF	SPI1IF	T3IF	T2IF	OC2IF	IC2IF	T1IF	OC1IF	IC1IF	INT0	0000 0000 0000 0000
IEC0	008C	CNIE	MI2CIE	SI2CIE	NVMIE	ADIE	U1TXIE	U1RXIE	SPI1IE	T3IE	T2IE	OC2IE	IC2IE	T1IE	OC1IE	IC1IE	INT0IE	0000 0000 0000 0000
IPC2	0098	—	ADIP<2:0>			—	U1TXIP<2:0>			—	U1RXIP<2:0>			—	SPI1IP<2:0>			0100 0100 0100 0100
ADCBUF0	0280	ADC Data Buffer 0																uuuu uuuu uuuu uuuu
ADCBUF1	0282	ADC Data Buffer 1																uuuu uuuu uuuu uuuu
ADCBUF2	0284	ADC Data Buffer 2																uuuu uuuu uuuu uuuu
ADCBUF3	0286	ADC Data Buffer 3																uuuu uuuu uuuu uuuu
ADCBUF4	0288	ADC Data Buffer 4																uuuu uuuu uuuu uuuu
ADCBUF5	028A	ADC Data Buffer 5																uuuu uuuu uuuu uuuu
ADCBUF6	028C	ADC Data Buffer 6																uuuu uuuu uuuu uuuu
ADCBUF7	028E	ADC Data Buffer 7																uuuu uuuu uuuu uuuu
ADCBUF8	0290	ADC Data Buffer 8																uuuu uuuu uuuu uuuu
ADCBUF9	0292	ADC Data Buffer 9																uuuu uuuu uuuu uuuu
ADCBUFA	0294	ADC Data Buffer 10																uuuu uuuu uuuu uuuu
ADCBUFB	0296	ADC Data Buffer 11																uuuu uuuu uuuu uuuu
ADCBUFC	0298	ADC Data Buffer 12																uuuu uuuu uuuu uuuu
ADCBUFD	029A	ADC Data Buffer 13																uuuu uuuu uuuu uuuu
ADCBUFE	029C	ADC Data Buffer 14																uuuu uuuu uuuu uuuu
ADCBUFF	029E	ADC Data Buffer 15																uuuu uuuu uuuu uuuu
ADCON1	02A0	ADON	—	ADSIDL	—	—	—	FORM<1:0>	SSRC<2:0>			—	SIMSAM	ASAM	SAMP	DONE	0000 0000 0000 0000	
ADCON2	02A2	VCFG<2:0>			—	—	CSCNA	CHPS<1:0>	BUFS	—	SMPI<3:0>					BUFM	ALTS	0000 0000 0000 0000
ADCON3	02A4	—	—	—	SAMC<4:0>				ADRC	—	ADCS<5:0>							0000 0000 0000 0000
ADCHS	02A6	CHXNB<1:0>		CHXSB	CH0NB	CH0SB<3:0>				CHXNA<1:0>	CHXSA	CH0NA	CH0SA<3:0>					0000 0000 0000 0000
ADPCFG	02A8	PCFG15	PCFG14	PCFG13	PCFG12	PCFG11	PCFG10	PCFG9	PCFG8	PCFG7	PCFG6	PCFG5	PCFG4	PCFG3	PCFG2	PCFG1	PCFG0	0000 0000 0000 0000
ADCSSL	02AA	CSSL<15:0>																0000 0000 0000 0000

Legend: u = unknown

Note: All interrupt sources and their associated control bits may not be available on a particular device. Refer to the device data sheet for details.

17.27 Design Tips

Question 1: *How can I optimize the system performance of the A/D converter?*

Answer:

1. Make sure you are meeting all of the timing specifications. If you are turning the module off and on, there is a minimum delay you must wait before taking a sample. If you are changing input channels, there is a minimum delay you must wait for this as well and finally, there is TAD, which is the time selected for each bit conversion. This is selected in ADCON3 and should be within a certain range as specified in the Electrical Characteristics. If TAD is too short, the result may not be fully converted before the conversion is terminated, and if TAD is made too long, the voltage on the sampling capacitor can decay before the conversion is complete. These timing specifications are provided in the “Electrical Specifications” section of the device data sheets.
2. Often the source impedance of the analog signal is high (greater than 10 k Ω), so the current drawn from the source to charge the sample capacitor can affect accuracy. If the input signal does not change too quickly, try putting a 0.1 μ F capacitor on the analog input. This capacitor will charge to the analog voltage being sampled and supply the instantaneous current needed to charge the 4.4 pF internal holding capacitor.
3. Put the device into Sleep mode before the start of the A/D conversion. The RC clock source selection is required for conversions in Sleep mode. This technique increases accuracy because digital noise from the CPU and other peripherals is minimized.

Question 2: *Do you know of a good reference on A/D's?*

Answer: A good reference for understanding A/D conversions is the “*Analog-Digital Conversion Handbook*” third edition, published by Prentice Hall (ISBN 0-13-03-2848-0).

Question 3: *My combination of channels/sample and samples/interrupt is greater than the size of the buffer. What will happen to the buffer?*

Answer: This configuration is not recommended. The buffer will contain unknown results.

17.28 Related Application Notes

This section lists application notes that are related to this section of the manual. These application notes may not be written specifically for the dsPIC30F Product Family, but the concepts are pertinent and could be used with modification and possible limitations. The current application notes related to the 10-bit A/D Converter module are:

Title	Application Note #
Using the Analog-to-Digital (A/D) Converter	AN546
Four Channel Digital Voltmeter with Display and Keyboard	AN557
Understanding A/D Converter Performance Specifications	AN693
Using the dsPIC30F for Sensorless BLDC Control	AN901
Using the dsPIC30F for Vector Control of an ACIM	AN908
Sensored BLDC Motor Control Using the dsPIC30F2010	AN957
An Introduction to AC Induction Motor Control Using the dsPIC30F MCU	AN984

Note: Please visit the Microchip web site (www.microchip.com) for additional Application Notes and code examples for the dsPIC30F Family of devices.
--

17.29 Revision History

Revision A

This is the initial released revision of this document.

Revision B

To reflect editorial and technical content revisions for the dsPIC30F 10-bit A/D Converter module.

Revision C

This revision incorporates all known errata at the time of this document update.

Revision D

This revision includes the extended conversion rate guidelines.

Revision E

- Added a paragraph to **17.11.2 “Automatic”**, which references automatic sampling and the TPDU parameter.
- Added **17.15 “Turning the A/D Module Off”**.
- Updated the sampling time (second to last bullet) in **17.23.1.3 “1 Msps Configuration Procedure”**.
- Incorporated minor changes to the document text.

NOTES: