



ELEMENTOS DE MÁQUINAS

Plan de Estudios 2013
Año 2026

TRENES DE ENGRANAJES

Tren de engranajes simple

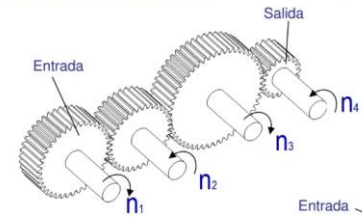

Tren de engranajes compuesto

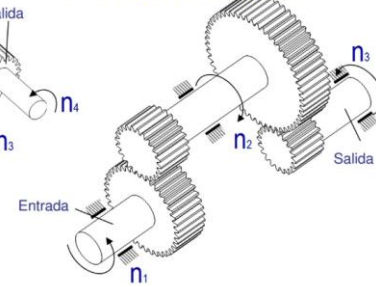

Ordinario { *Simple*
Compuesto
Coaxial

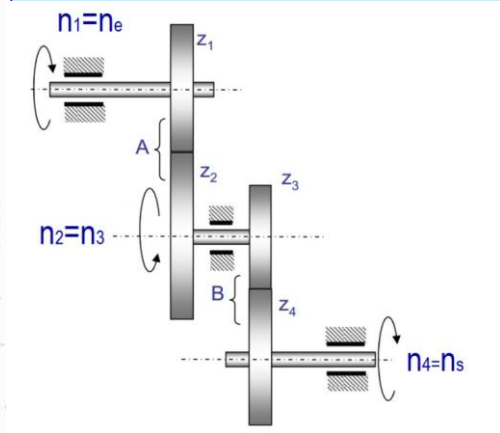

Trenes {

Planetario { *Plano*
Esférico



RUEDAS DENTADAS

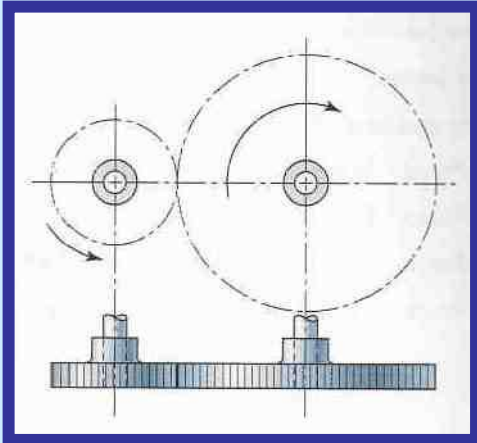

**Ruedas dentadas de
dientes rectos**

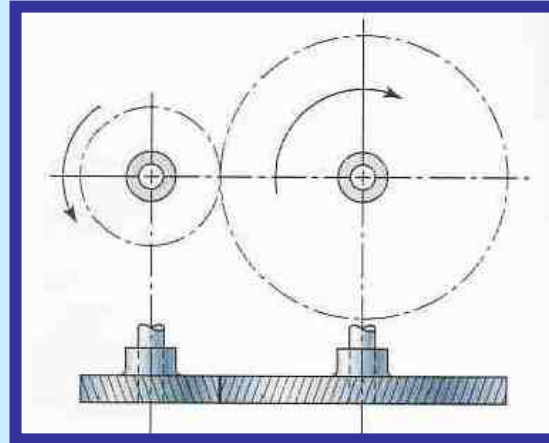

**Ruedas dentadas de
dientes helicoidales**

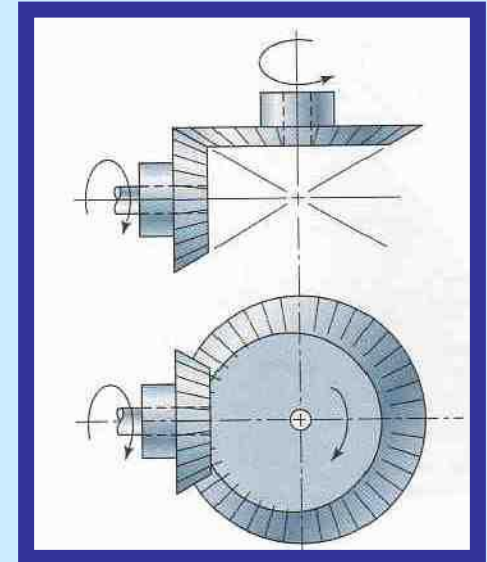

**Ruedas dentadas cónicas
de dientes rectos**

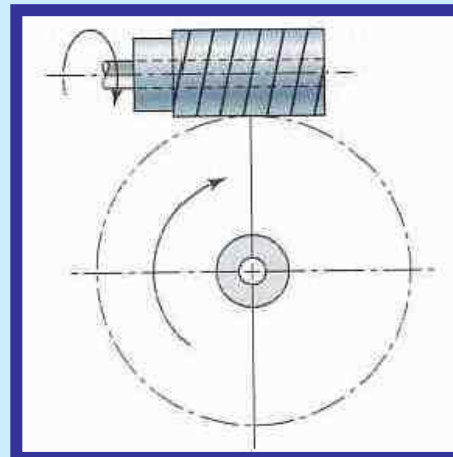

**Tornillo Sin Fin – Rueda
helicoidal**

TREN ORDINARIO SIMPLE

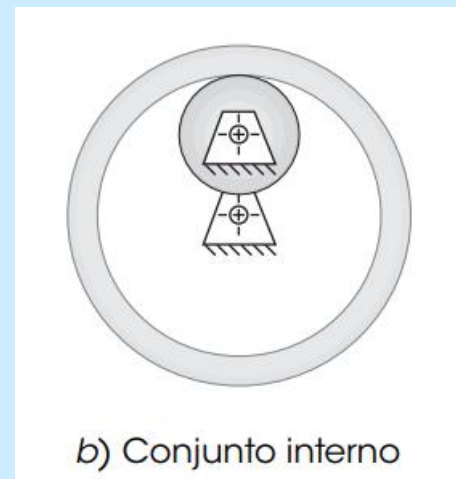
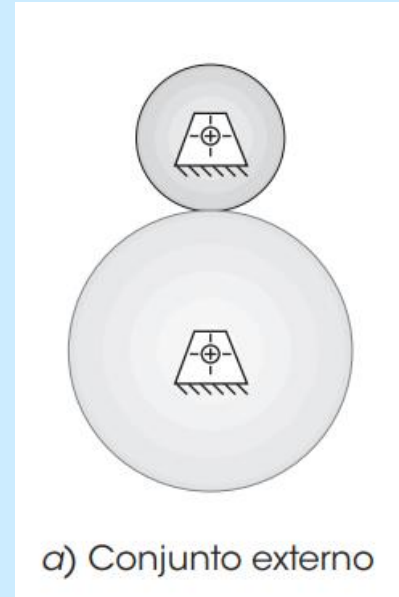
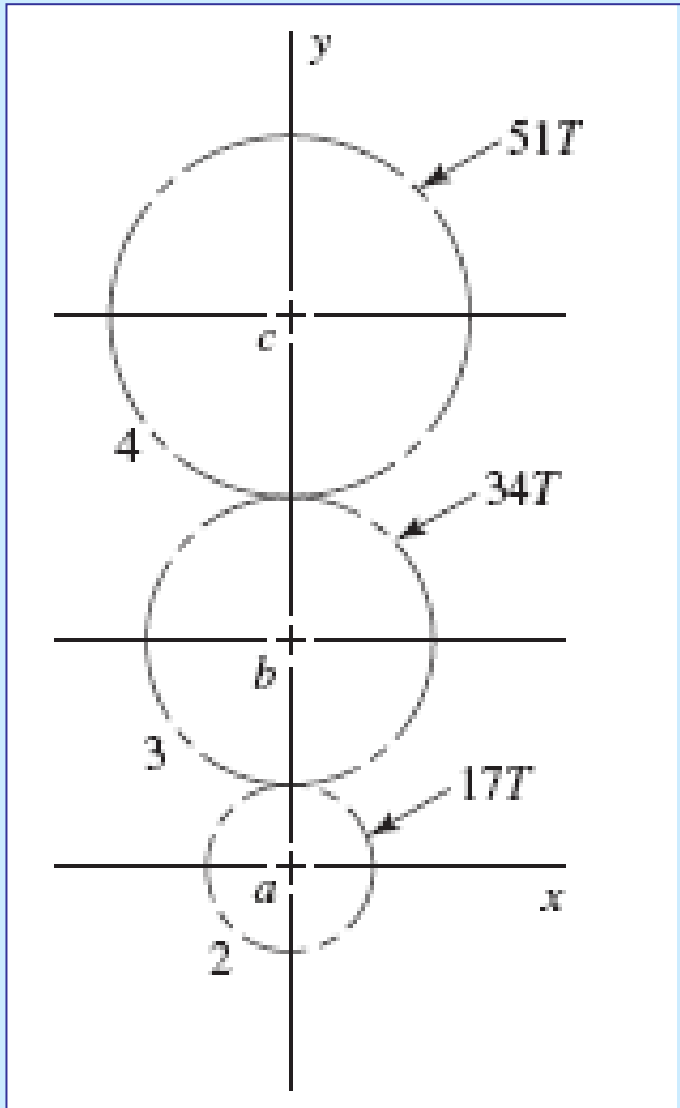

$$\frac{\omega_{sal}}{\omega_{ent}} = \pm \frac{r_{ent}}{r_{sal}} = \pm \frac{d_{ent}}{d_{sal}}$$

TREN ORDINARIO COMPUESTO

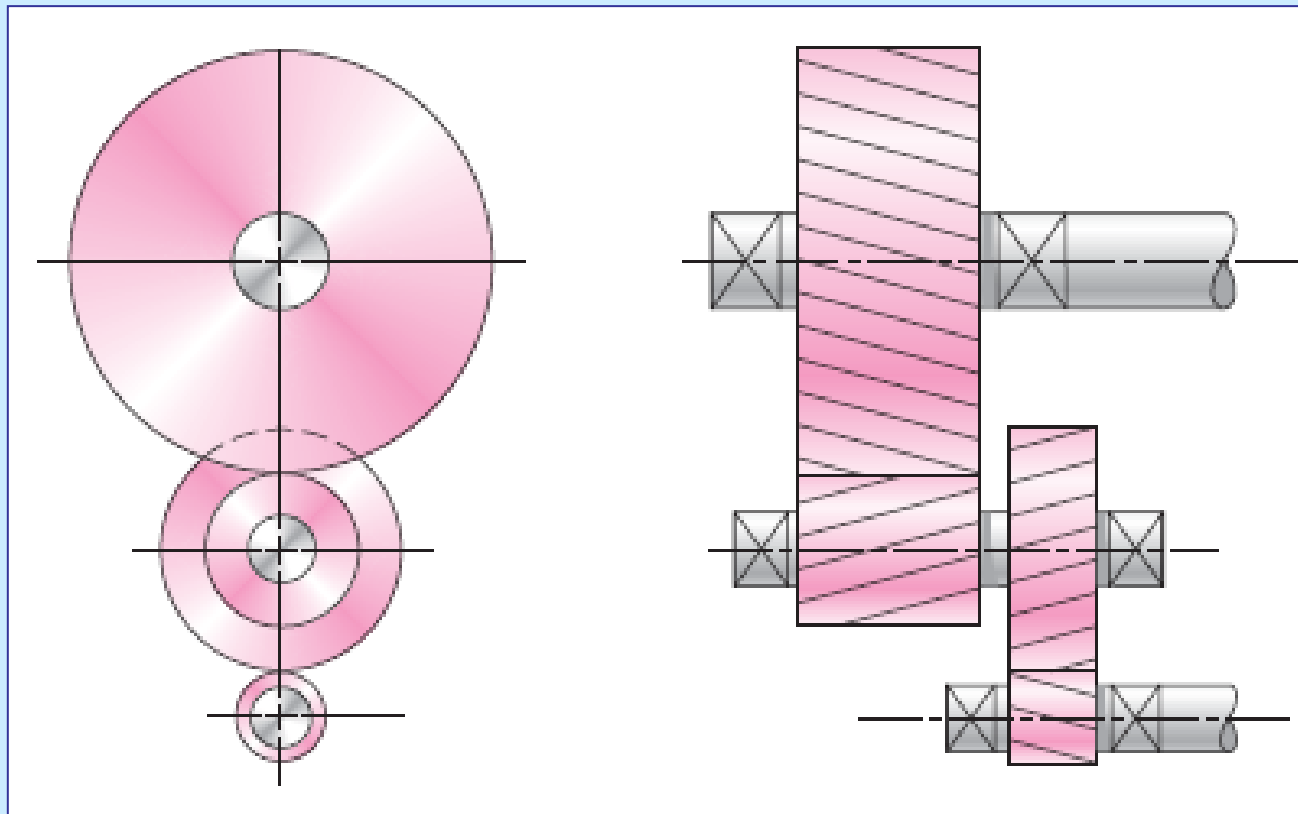

TREN ORDINARIO COAXIAL

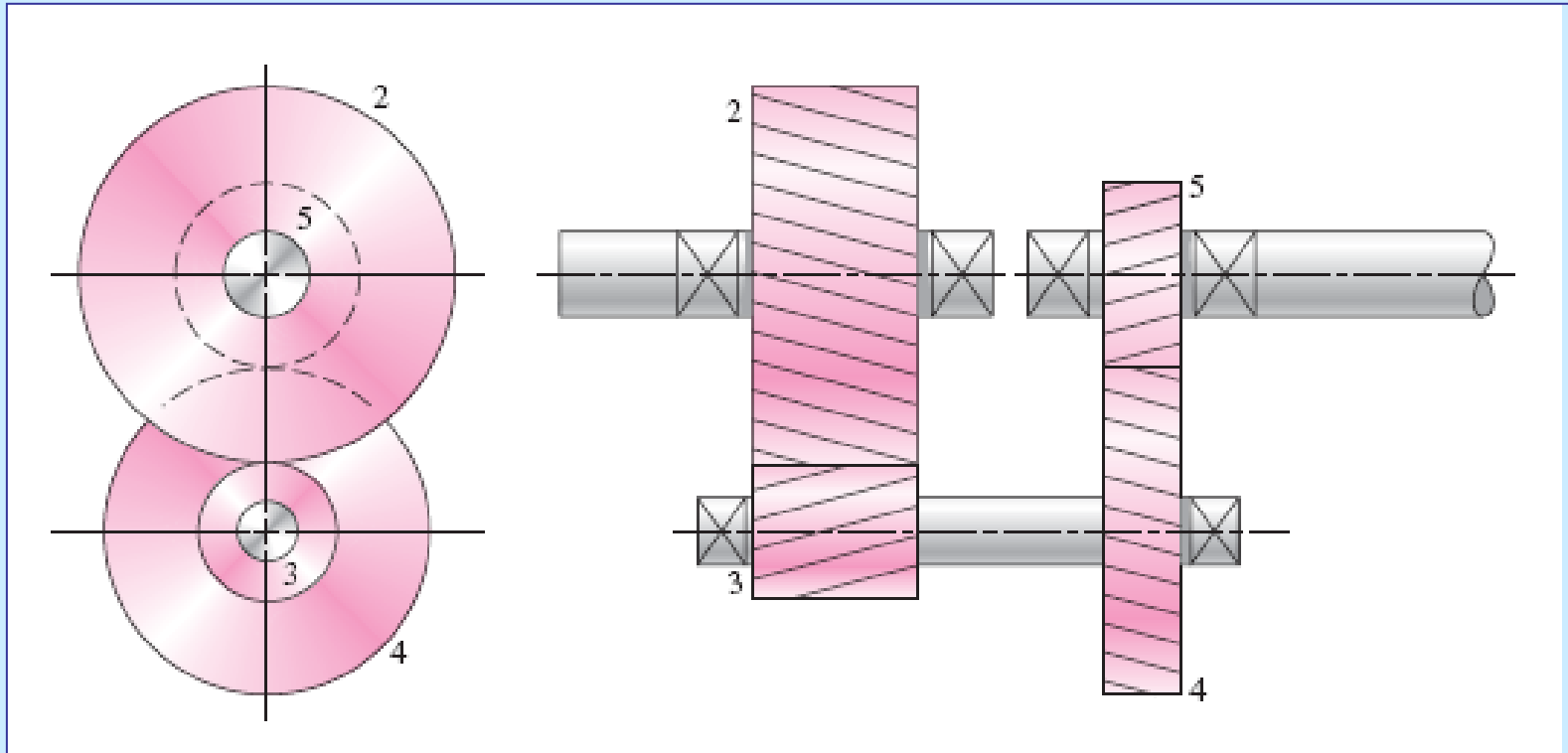

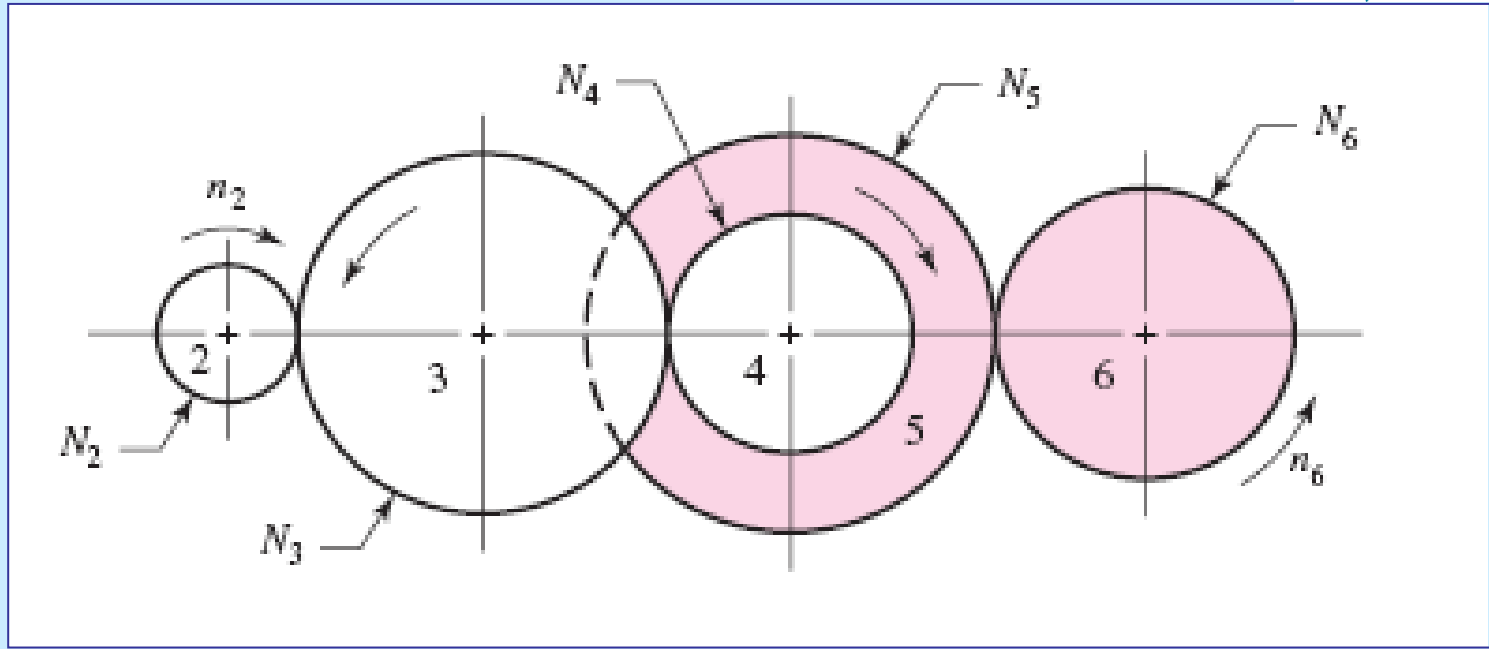

$e = \frac{\text{producto de los números de dientes impulsores}}{\text{producto de los números de dientes impulsados}}$

$$n_6 = -\frac{N_2}{N_3} \frac{N_3}{N_4} \frac{N_5}{N_6} n_2$$

e : valor del tren

$$\left(-\frac{N_2}{N_3}\right) \left(-\frac{N_3}{N_4}\right) \left(-\frac{N_4}{N_5}\right) \left(-\frac{N_5}{N_6}\right) = +\frac{N_2}{N_6}$$

$$n_L = en_F$$

TREN PLANETARIO PLANO

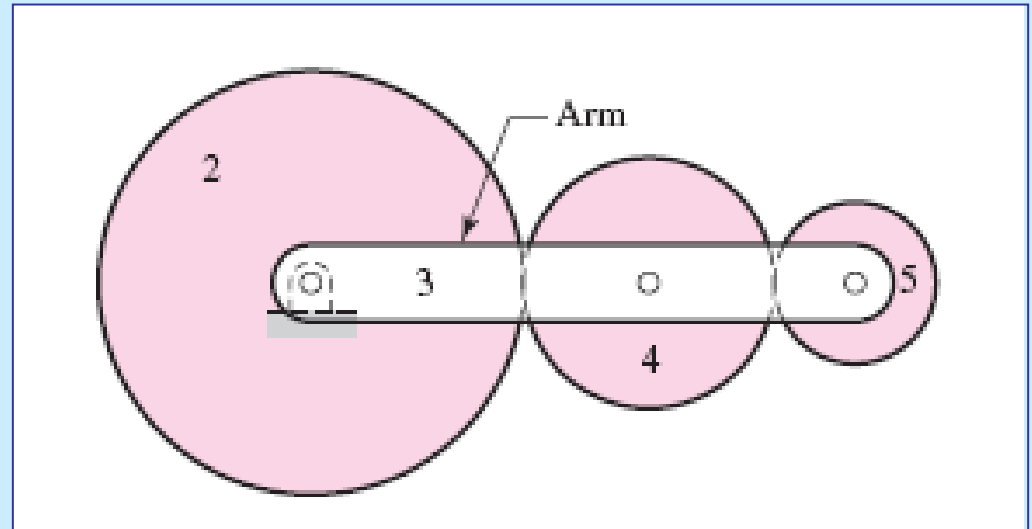
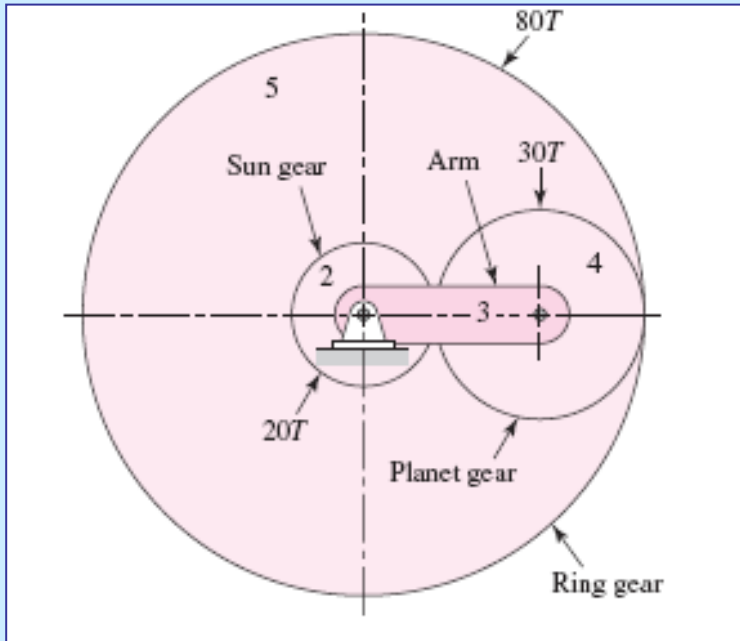

Fórmula de Willis

$$n_{23} = n_2 - n_3$$

$$n_{53} = n_5 - n_3$$

$$\frac{n_{53}}{n_{23}} = \frac{n_5 - n_3}{n_2 - n_3}$$

$$e = \frac{n_5 - n_3}{n_2 - n_3}$$

$$e = \frac{n_L - n_A}{n_F - n_A}$$

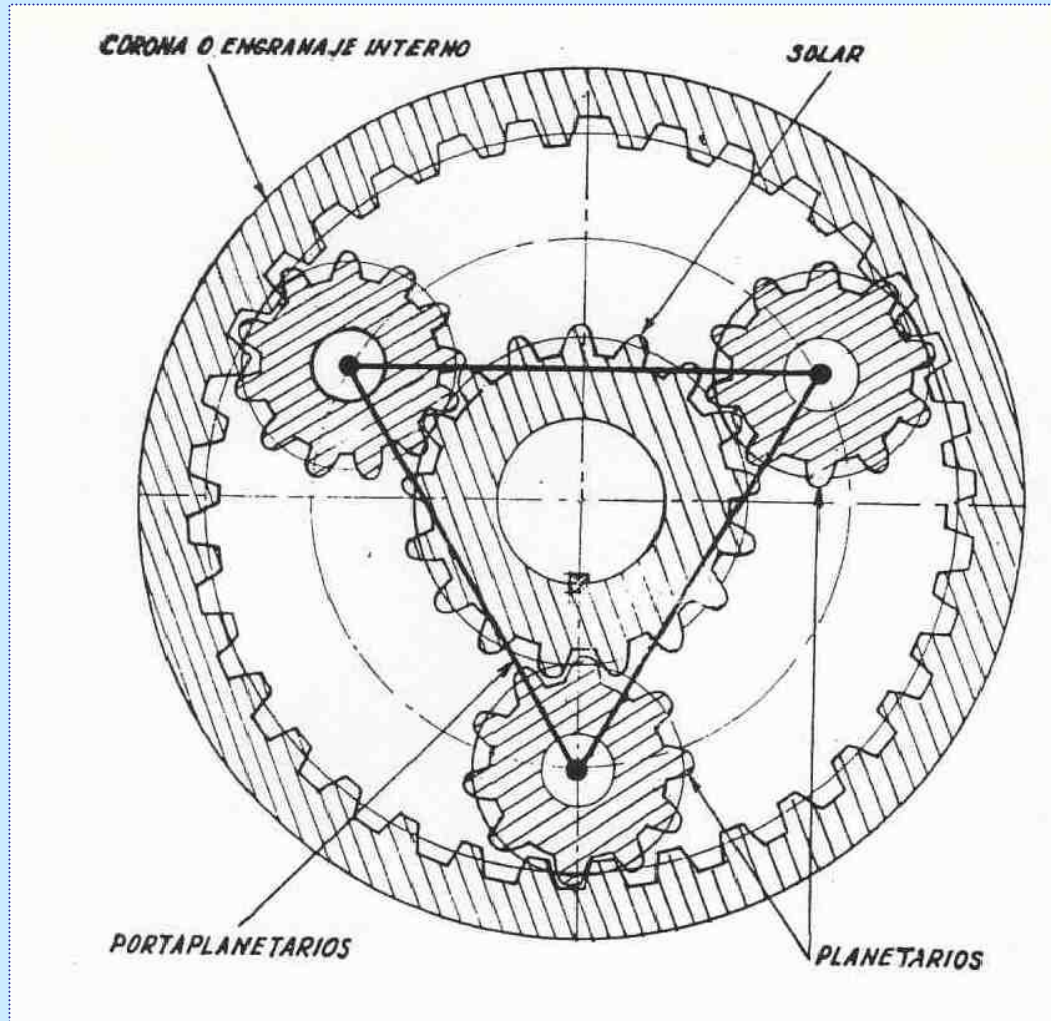

https://www.google.com/search?q=tren+de+engrane+oplaneta+usos&bih=746&biw=1536&rlz=1C1GCEA_enAR1034AR1034hl=es-419&tbn=vid&sxsrf=APwXEddDnQoO2iXm6yrU4esY7nb7qf2g%3A1684722647551&ei=19NqZlugiZLY1sQP-aGA-A18yod_9chLjKE-wil_58728lf_AbLjS-lljClfkrQAG8Q4dLUDCA

TREN PLANETARIO ESFÉRICO

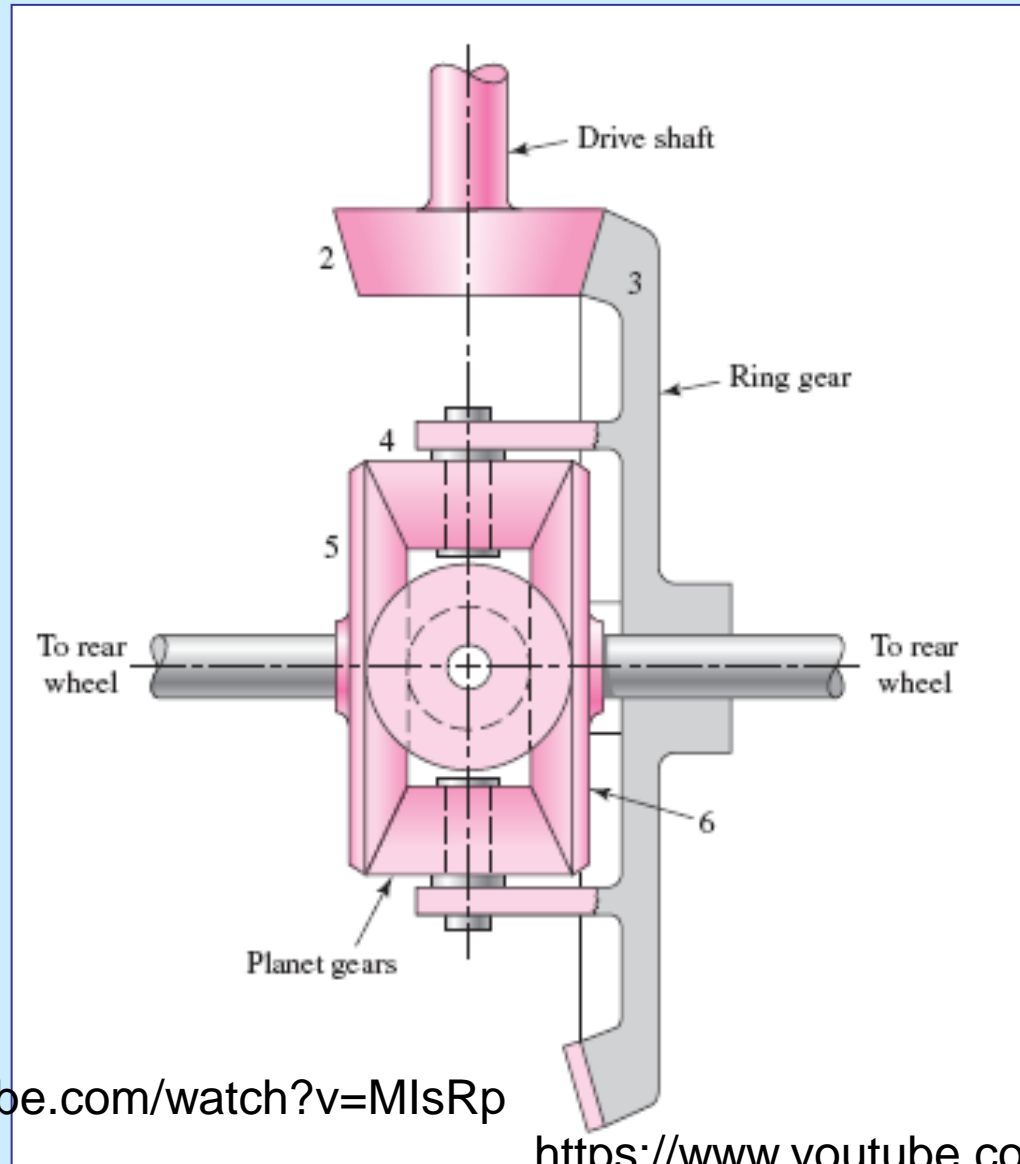

<https://www.youtube.com/watch?v=MIsRpWqCNew>

<https://www.youtube.com/watch?v=E9xh1s nxK3Q>

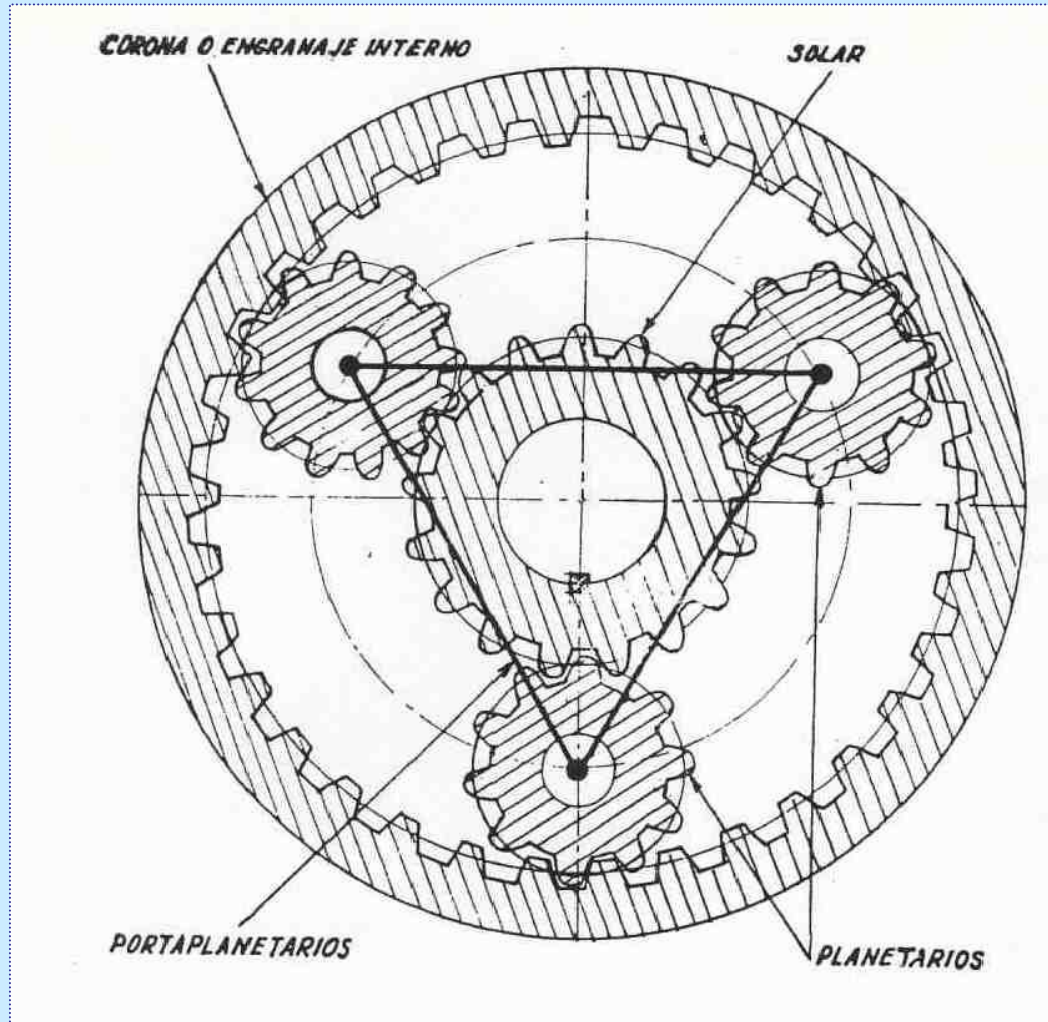

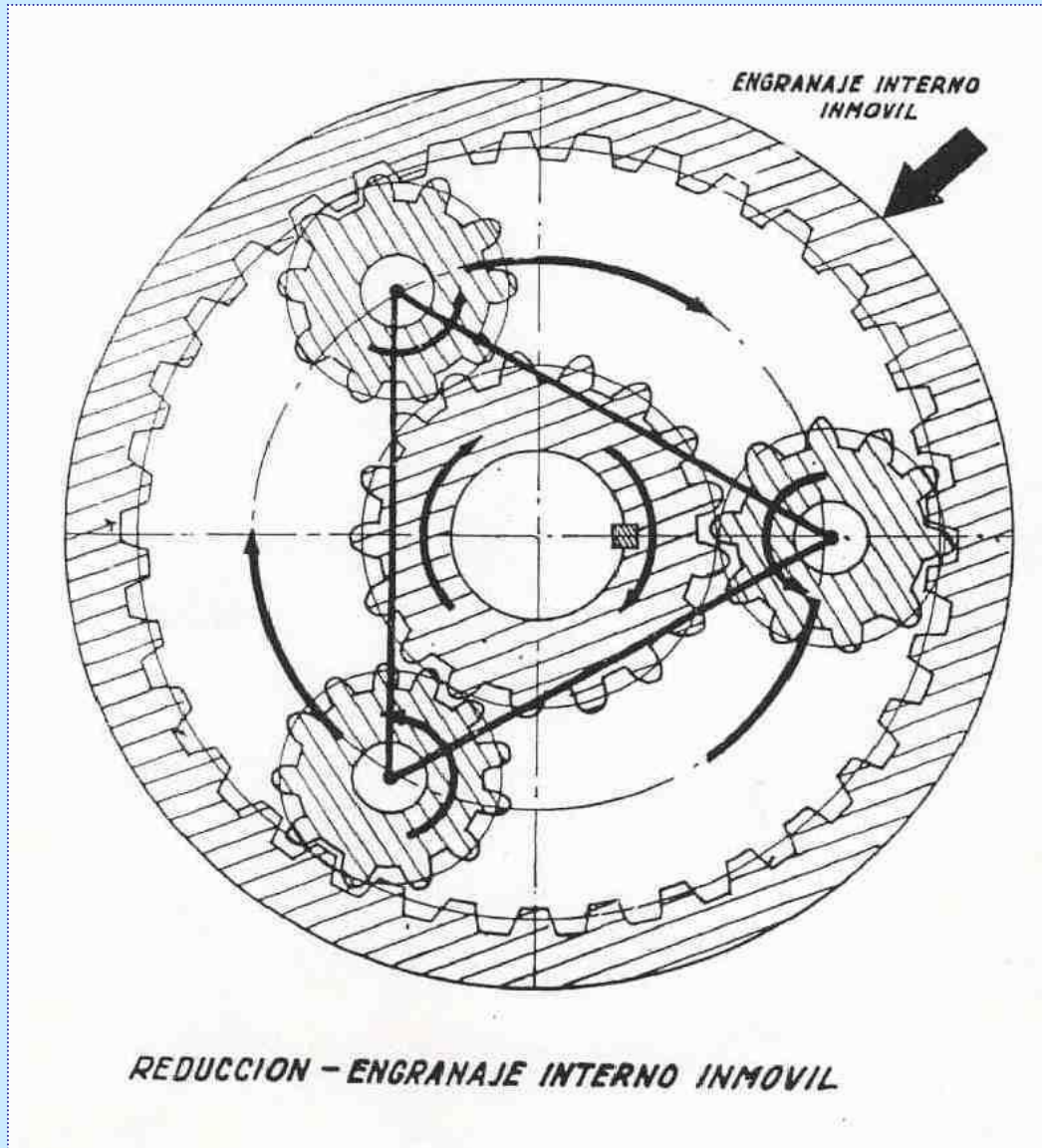

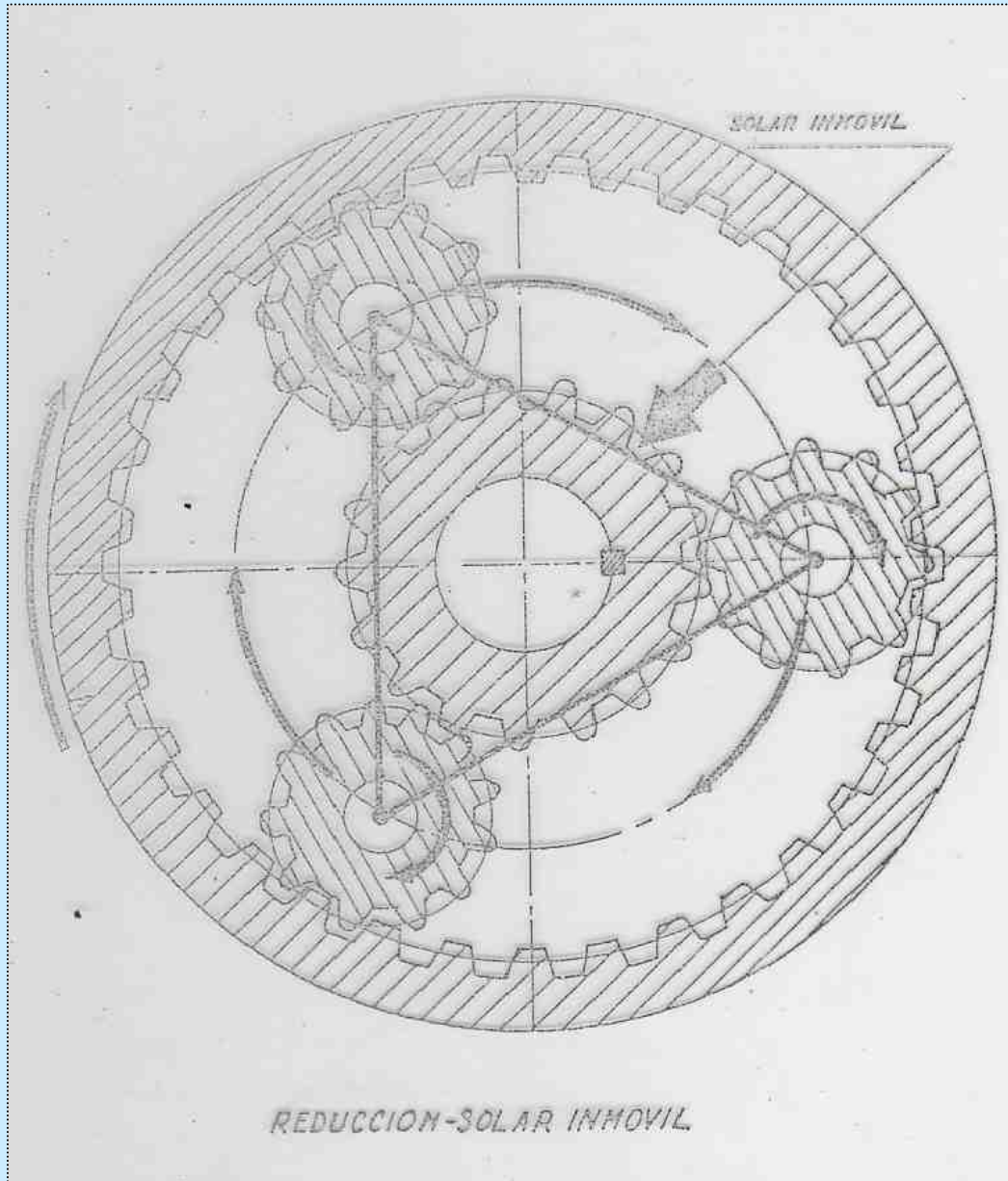

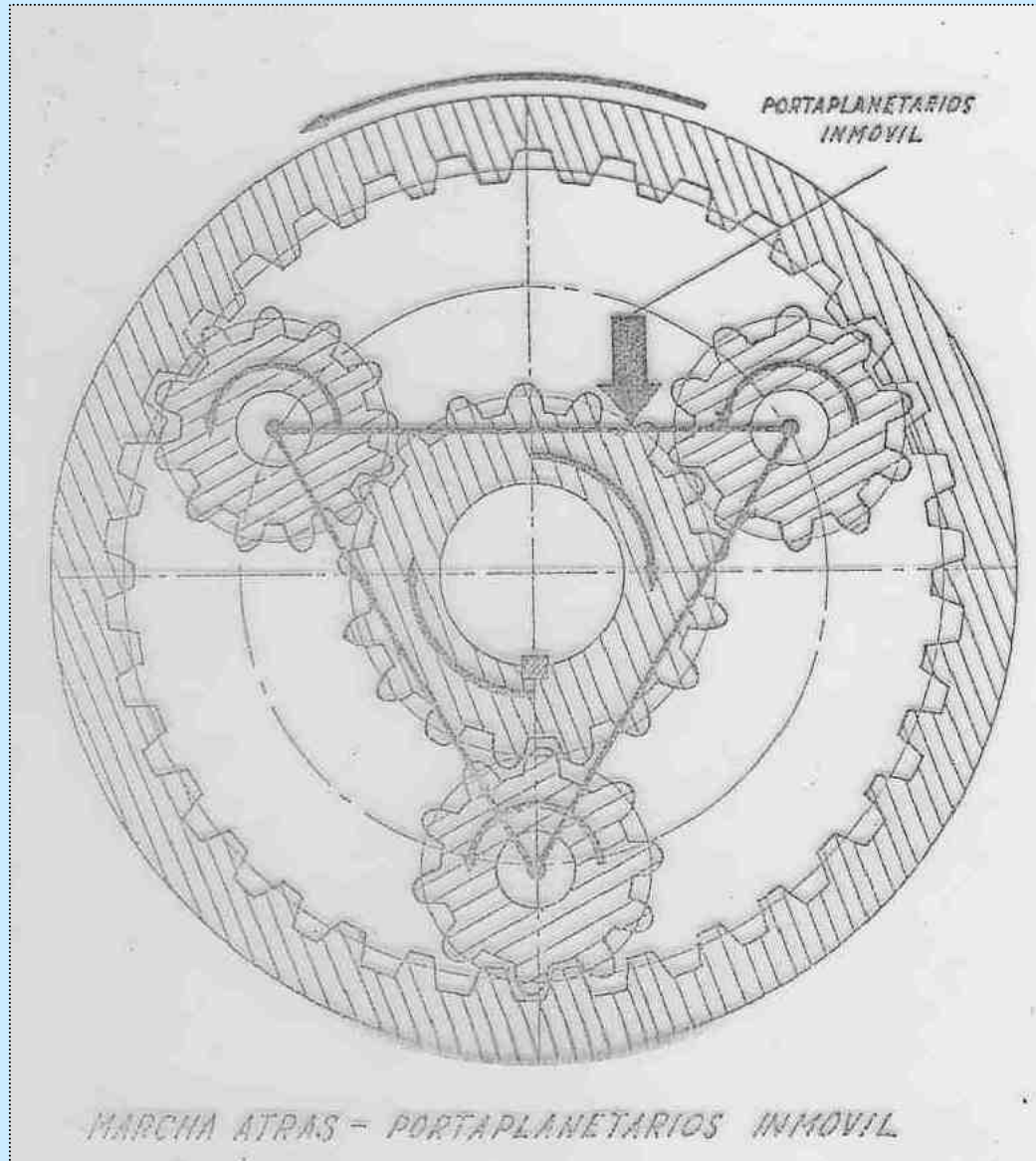

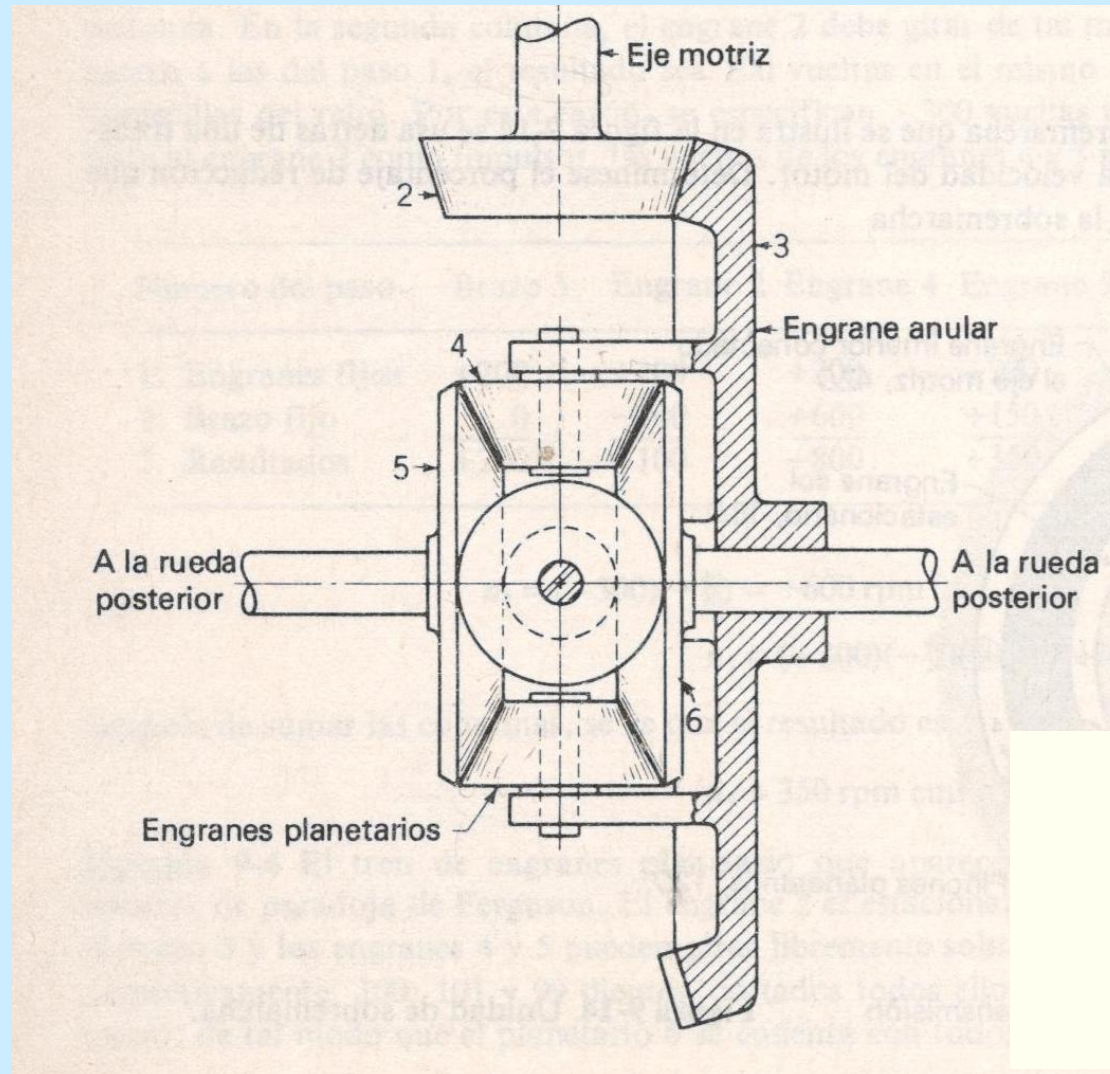

Dibujo esquemático de un diferencial automotriz de engranes cónicos

Ejemplo

Diseñe un tren compuesto revertido con una relación exacta de 18:1

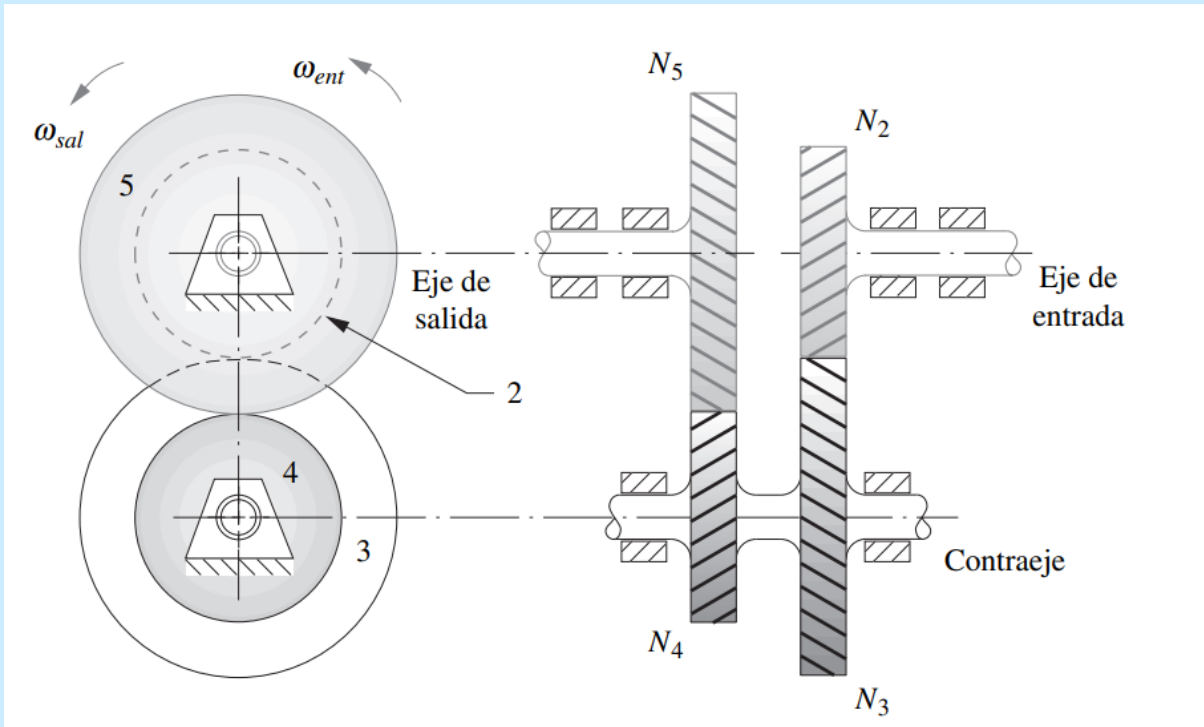

Relación de engrane	N° Dientes Piñon	N° Dientes Engrane
7,071	12	84,852
7,071	13	91,923
7,071	14	98,994
7,071	15	106,065
7,071	16	113,136
7,071	17	120,207
7,071	18	127,278
7,071	19	134,349

Ejemplo 50:1 tomo la raíz cuadrada para definir si es de dos etapas o mas.

Si es mayor a 10:1 la raíz cuadrada debo pasar a la próxima potencia

$$\sqrt{50} = 7,071$$

Otro factor importante es la distancia entre centros que debe mantenerse constante.

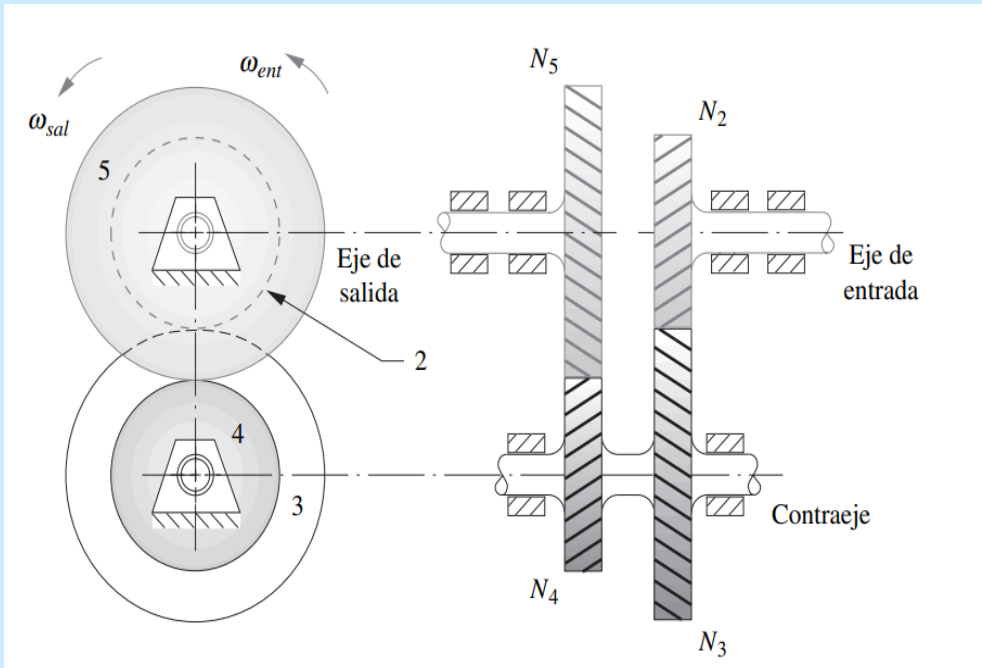

Ejemplo 50:1 $\sqrt{50} = 7,071$

$9 \times 6 = 54$
 50:1 $7 \times 7 = 49$
 $? \times ? = 50$

La distancia entre centros que debe mantenerse constante.

$$N_2 + N_3 = N_4 + N_5 = K$$

$$e = \pm \frac{\text{producto de los números de dientes impulsores}}{\text{producto de los números de dientes impulsados}}$$

