

LOCAL AREA NETWORK OVERVIEW

11.1 Bus and Tree Topologies and Transmission Media

- Topologies
- Choice of Topology
- Choice of Transmission Medium

11.2 Lan Protocol Architecture

- IEEE 802 Reference Model
- Logical Link Control
- Medium Access Control

11.3 Bridges

- Functions of a Bridge
- Bridge Protocol Architecture
- Fixed Routing
- The Spanning Tree Approach

11.4 Hubs and Switches

- Hubs
- Layer 2 Switches

11.5 Virtual LANs

- The Use of Virtual LANs
- Defining VLANs
- Communicating VLAN Membership

11.6 Recommended Reading and Animations



11.7 Key Terms, Review Questions, and Problems

LEARNING OBJECTIVES

After studying this chapter, you should be able to:

- ◆ Distinguish between bus and star topologies.
- ◆ Explain the IEEE 802 reference model.
- ◆ Present an overview of logical link control.
- ◆ Understand the functionality of bridges.
- ◆ Distinguish between hubs and switches.
- ◆ Present an overview of virtual LANs.

This chapter begins our discussion of **local area networks (LANs)**. Whereas wide area networks may be public or private, LANs usually are owned by the organization that is using the network to interconnect equipment. LANs have much greater capacity than wide area networks to carry what is generally a greater internal communications load.

In this chapter, we look at the underlying technology and protocol architecture of LANs. Chapters 12 and 13 are devoted to a discussion of specific LAN systems.

11.1 BUS AND STAR TOPOLOGIES

In the context of a communication network, the term *topology* refers to the way in which the endpoints, or stations, attached to the network are interconnected. Historically, common topologies for LANs are bus, tree, ring, and star. In contemporary LANs, the star topology, based around the use of switches, dominates. However, it is useful to briefly look at the operation of the bus topology because it shares some characteristics with wireless LANs, and key elements of wireless LAN access protocols evolved from bus LAN access protocols. In this section, we first describe the bus topology, and then introduce the star topology.

Bus Topology

In the **bus topology**, all stations attach, through appropriate hardware interfacing known as a tap, **directly to a linear transmission medium, or bus**. Full-duplex operation between the station and the tap allows data to be transmitted onto the bus and received from the bus. A transmission from any station propagates the length of the

Analogía: voz, aire , el aire es el bus. Todos compartimos el medio.

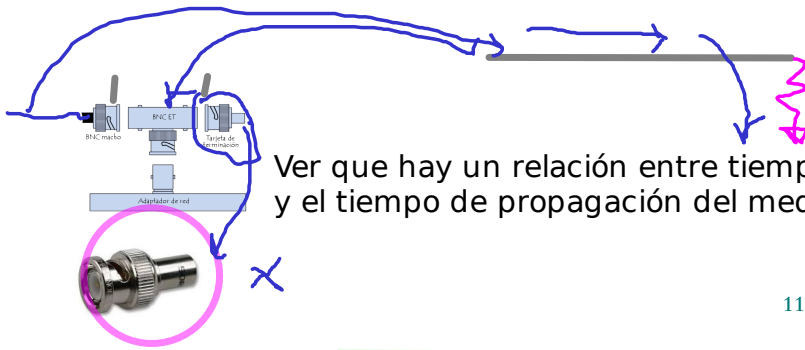

Ver que hay un relación entre tiempo de transmisión de un mensaje y el tiempo de propagación del medio.

bus común: Multipunto **medium in both directions and can be received by all other stations.** At each end of the bus is a terminator, **which absorbs any signal, removing it from the bus.**

Problemas

- 1) Todas est. escuchan
- 2) Quien controla?

- uso excesivo.
- colisión

Two problems present themselves in this arrangement. First, because a transmission from any one station can be received by all other stations, there needs to be some way of indicating for whom the transmission is intended. Second, a mechanism is needed to regulate transmission. To see the reason for this, consider that if two stations on the bus attempt to transmit at the same time, their signals will overlap and become garbled. Or consider that if one station decides to transmit continuously for a long period of time, other stations will be blocked from transmitting.

trama: **header+ dato+ control**

To **solve these problems**, stations transmit **data in small blocks, known as frames.** Each frame consists of a portion of the data that a station wishes to transmit, plus a frame header that contains control information. Each station on the bus is **assigned a unique address, or identifier, and the destination address for a frame is included in its header.**

id o dir en header.

EXAMPLE 11.1 Figure 11.1 illustrates the bus scheme. In this example, station C wishes to transmit a frame of data to A. The frame header includes A's address. As the frame propagates along the bus, it passes B. B observes the address and ignores the frame. A, on the other hand, sees that the frame is addressed to itself and therefore copies the data from the frame as it goes by.

So the frame structure solves the first problem mentioned previously: It provides a mechanism for indicating the intended recipient of data. It also provides the basic tool for solving the second problem, the regulation of access. In particular, the stations take turns sending frames in some cooperative fashion. This involves putting additional control information into the frame header, as discussed later.

No special action needs to be taken to remove frames from the bus. When a signal reaches the end of the bus, it is absorbed by the terminator.

Star Topology

Nodo Central

Punto a punto-

In the **star** LAN topology, each station is directly connected to **a common central node (Figure 11.2).** Typically, each station attaches to a central node **via two point-to-point links**, one for transmission and one for reception.

In general, there are **two alternatives** for the operation of the central node. **One approach is for the central node to operate in a broadcast fashion.** A transmission of a frame from one station to the node is retransmitted on all of the outgoing links. In this case, although the **arrangement is physically a star, it is logically a bus:** A transmission from any station is received by all other stations, and only one station at a time may successfully transmit. In this case, the **central element is referred to as a hub.** Another approach is for the **central node to act as a frame-switching device.** An incoming frame is buffered in the node and then retransmitted on an outgoing link to the destination station. These approaches are explored in Section 11.4.

2 Alternativas.

Broadcast -> Logicamente como bus , no estrella, Nodo central : HUB

Conmutación de tramas -> punto a punto lógicamente : estrella , Nodo central Switch

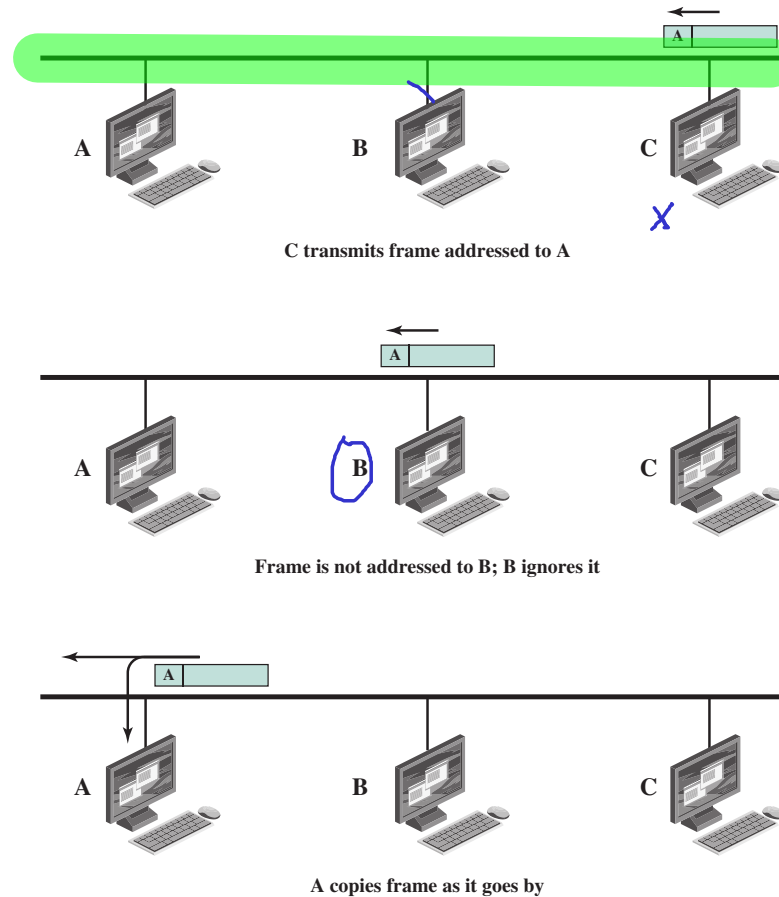

Figure 11.1 Frame Transmission on a Bus LAN

11.2 LAN PROTOCOL ARCHITECTURE

Lan protocol
 * Físico
 * Acceso al medio MAC
 * Control lógico LLC

The architecture of a LAN is best described in terms of a layering of protocols that organize the basic functions of a LAN. This section opens with a description of the standardized protocol architecture for LANs, which encompasses physical, medium access control (MAC), and logical link control (LLC) layers. This section then provides an overview of the MAC and LLC layers.

IEEE 802 Reference Model

Protocols defined specifically for LAN and metropolitan area networks (MAN) transmission address issues relating to the transmission of blocks of data over the network. In OSI (open systems interconnection) terms, higher layer protocols (layer 3 or 4 and above) are independent of network architecture and are applicable

OSI: El modelo de comunicaciones que propone es capas Independientes.

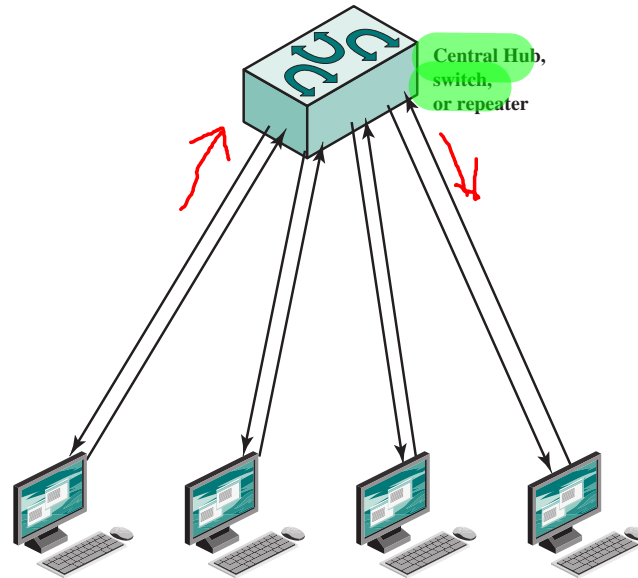

Figure 11.2 Star Topology

to LANs, MANs, and WANs. Thus, a discussion of LAN protocols is concerned principally with lower layers of the OSI model.

Figure 11.3 relates the LAN protocols to the OSI architecture. This architecture was developed by the IEEE 802 LAN standards committee¹ and has been adopted by all organizations working on the specification of LAN standards. It is generally referred to as the IEEE 802 reference model.

Working from the bottom-up, the lowest layer of the IEEE 802 reference model corresponds to the physical layer of the OSI model and includes such functions as

- Encoding/decoding of signals
- Preamble generation/removal (for synchronization)
- Bit transmission/reception

In addition, the physical layer of the 802 model includes a specification of the transmission medium and the topology. Generally, this is considered “below” the lowest layer of the OSI model. However, the choice of transmission medium and topology is critical in LAN design, and so a specification of the medium is included.

Above the physical layer are the functions associated with providing service to LAN users. These include the following:

- On transmission, assemble data into a frame with address and error-detection fields.
- On reception, disassemble frame and perform address recognition and error detection.

¹This committee has developed standards for a wide range of LANs. See Appendix C for details.

Capa 1:Física.

3 Funciones

Medios de Trasm,
Topología

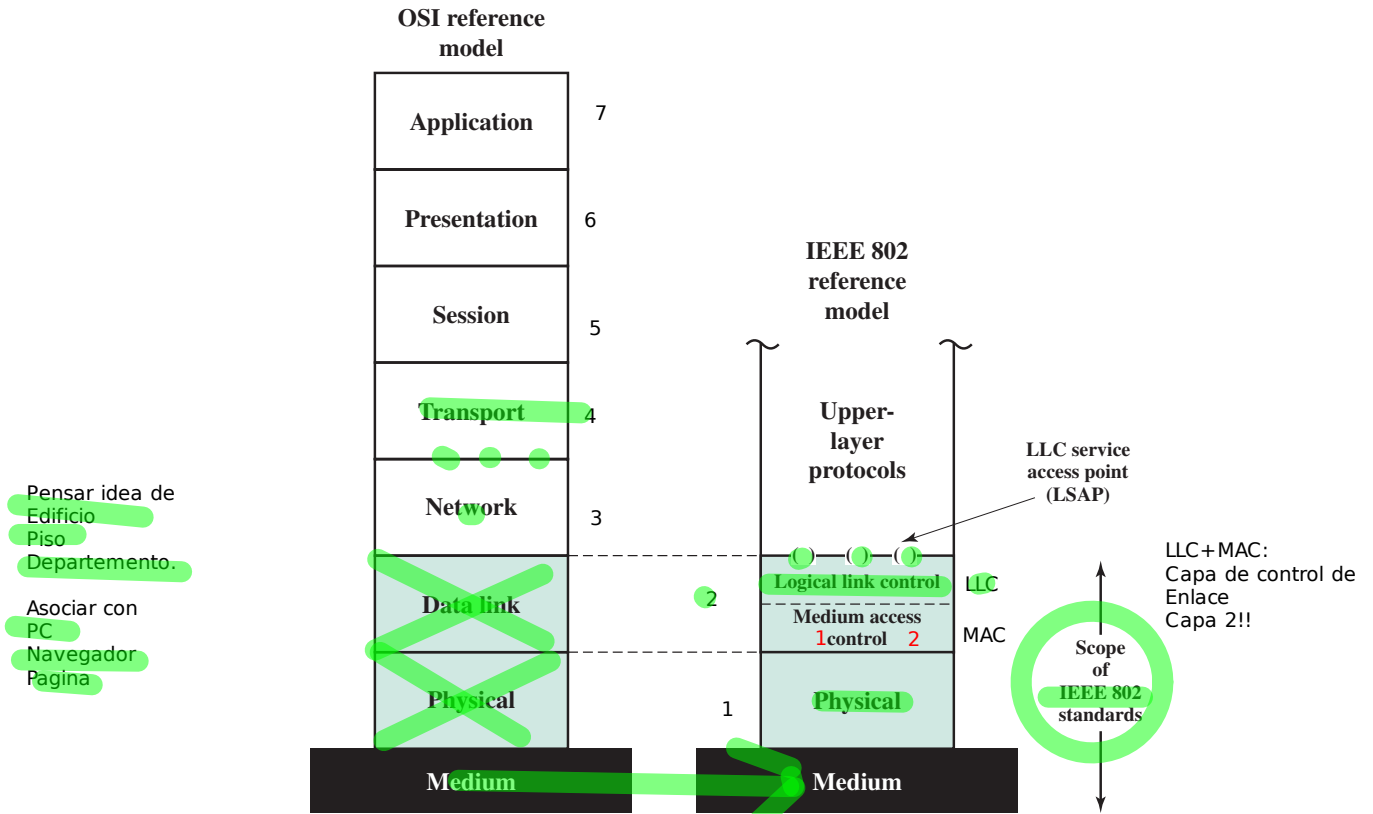

Figure 11.3 IEEE 802 Protocol Layers Compared to OSI Model

- Govern access to the LAN transmission medium.
- Provide an interface to higher layers and perform flow and error control.

These are functions typically associated with OSI layer 2. The set of functions in the last bullet item are grouped into a **logical link control (LLC)** layer. The functions in the first three bullet items are treated as a separate layer, called **medium access control (MAC)**. The separation is done for the following reasons:

- The logic required to manage access to a shared-access medium is not found in traditional layer 2 data link control.
- For the same LLC, several MAC options may be provided.

Figure 11.4 illustrates the relationship between the levels of the architecture (compare Figure 2.5). Higher-level data are passed down to LLC, which appends control information as a header, creating an *LLC protocol data unit (PDU)*. This control information is used in the operation of the LLC protocol. The entire LLC PDU is then passed down to the MAC layer, which appends control information at the front and back of the packet, forming a *MAC frame*. Again, the control information in the frame is needed for the operation of the MAC protocol. For context,

Pensar idea de Edificio
Piso
Departamento.

Asociar con PC
Navegador
Pagina

¿Por que hay separación de capa 2?

La lógica de acceso al medio no es parte del control de enlace tradicionalmente.

varias placas => varias MAC pero un solo LLC

LLC+MAC:
Capa de control de Enlace
Capa 2!!

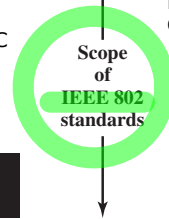

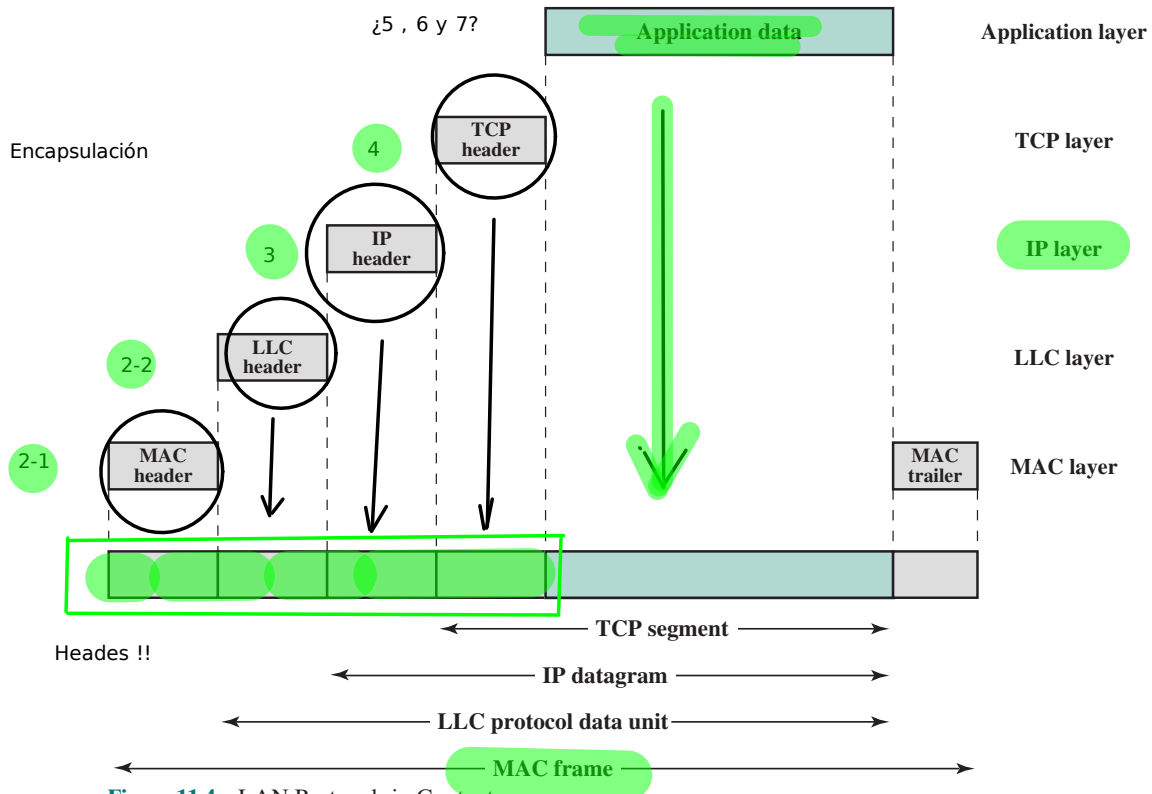

Figure 11.4 LAN Protocols in Context

the figure also shows the use of TCP/IP and an application layer above the LAN protocols.

Logical Link Control

The LLC layer for LANs is similar in many respects to other link layers in common use. Like all link layers, LLC is concerned with the transmission of a link-level PDU between two stations, without the necessity of an intermediate switching node. LLC has two characteristics not shared by most other link control protocols:

1. It must support the multiaccess, shared-medium nature of the link (this differs from a multidrop line in that there is no primary node).
2. It is relieved of some details of link access by the MAC layer.

Addressing in LLC involves specifying the source and destination LLC users. Typically, a user is a higher-layer protocol or a network management function in the station. These LLC user addresses are referred to as service access points (SAPs), in keeping with OSI terminology for the user of a protocol layer.

Departamentos.

We look first at the services that LLC provides to a higher-level user, and then at the LLC protocol.

Observación. Un medio compartido de acceso múltiple, no es lo mismo que algo parecido al bus. En el Bus NO hay un nodo central. Si en este caso de acceso múltiple con medio compartido.

338 CHAPTER 11 / LOCAL AREA NETWORK OVERVIEW

LLC SERVICES. LLC specifies the mechanisms for addressing stations across the medium and for controlling the exchange of data between two users. The operation and format of this standard is based on HDLC (high-level data link control). Three services are provided as alternatives for attached devices using LLC:

Si hay problemas, no me miren a mí...

- **Unacknowledged connectionless service:** This service is a datagram-style service. It is a very simple service that does not involve any of the flow- and error-control mechanisms. Thus, the delivery of data is not guaranteed. However, in most devices, there will be some higher layer of software that deals with reliability issues. : como cartas...

Si hay problemas yo me encargo..

- **Connection-mode service:** This service is similar to that offered by HDLC. A logical connection is set up between two users exchanging data, and flow control and error control are provided. : como comunicacion telefónica.

responsabilidad intermedia

- **Acknowledged connectionless service:** This is a cross between the previous two services. It provides that datagrams are to be acknowledged, but no prior logical connection is set up. => no se garantiza orden, si un ACK de Datagrama

Typically, a vendor will provide these services as options that the customer can select when purchasing the equipment. Alternatively, the customer can purchase equipment that provides two or all three services and select a specific service based on application.

The **unacknowledged connectionless service** requires minimum logic and is useful in two contexts. First, it will often be the case that higher layers of software will provide the necessary reliability and flow-control mechanism, and it is efficient to avoid duplicating them. For example, TCP could provide the mechanisms needed to ensure that data is delivered reliably. Second, there are instances in which the overhead of connection establishment and maintenance is unjustified or even counterproductive (e.g., data collection activities that involve the periodic sampling of data sources, such as sensors and automatic self-test reports from security equipment or network components). In a monitoring application, the loss of an occasional data unit would not cause distress, as the next report should arrive shortly. Thus, in most cases, the unacknowledged connectionless service is the preferred option.

Mas usado: Connectionless.

The **connection-mode service** could be used in very simple devices, such as terminal controllers, that have little software operating above this level. In these cases, it would provide the flow control and reliability mechanisms normally implemented at higher layers of the communications software.

The **acknowledged connectionless service** is useful in several contexts. With the connection-mode service, the logical link control software must maintain some sort of table for each active connection, to keep track of the status of that connection. If the user needs guaranteed delivery but there are a large number of destinations for data, then the connection-mode service may be impractical because of the large number of tables required. An example is a process control or automated factory environment where a central site may need to communicate with a large number of processors and programmable controllers. Another use of this is the handling of important and time-critical alarm or emergency control signals in a factory. Because of their importance, an acknowledgment is needed so that the sender can be assured that the signal got through. Because of the urgency of the signal, the user

might not want to take the time first to establish a logical connection and then send the data.

LLC PROTOCOL The basic LLC protocol is modeled after HDLC and has similar functions and formats. The differences between the two protocols can be summarized as follows:

- LLC makes use of the asynchronous balanced mode of operation of HDLC, to support connection-mode LLC service; this is referred to as type 2 operation. The other HDLC modes are not employed.
- LLC supports an unacknowledged connectionless service using the unnumbered information PDU; this is known as type 1 operation.
- LLC supports an acknowledged connectionless service by using two new unnumbered PDUs; this is known as type 3 operation.
- LLC permits multiplexing by the use of LLC service access points (LSAPs).

All three LLC protocols employ the same PDU format (Figure 11.5), which consists of four fields. The DSAP (Destination Service Access Point) and SSAP (Source Service Access Point) fields each contain a 7-bit address, which specifies the destination and source users of LLC. One bit of the DSAP indicates whether the DSAP is an individual or group address. One bit of the SSAP indicates whether the PDU is a command or response PDU. The format of the LLC control field is identical to that of HDLC (Figure 7.7), using extended (7-bit) sequence numbers.

For type 1 operation, which supports the unacknowledged connectionless service, the unnumbered information (UI) PDU is used to transfer user data. There is no acknowledgment, flow control, or error control. However, there is error detection and discard at the MAC level.

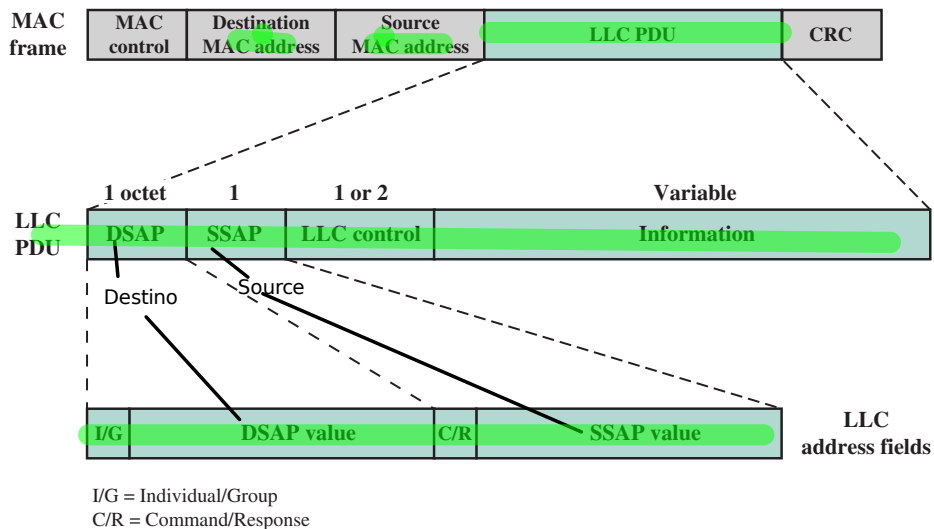

Figure 11.5 LLC PDU in a Generic MAC Frame Format

Two other PDUs are used to support management functions associated with all three types of operation. Both PDUs are used in the following fashion. An LLC entity may issue a command (C/R bit = 0) XID or TEST. The receiving LLC entity issues a corresponding XID or TEST in response. The XID PDU is used to exchange two types of information: types of operation supported and window size. The TEST PDU is used to conduct a loopback test of the transmission path between two LLC entities. Upon receipt of a TEST command PDU, the addressed LLC entity issues a TEST response PDU as soon as possible.

With **type 2 operation**, a data link connection is established between two LLC SAPs prior to data exchange. Connection establishment is attempted by the type 2 protocol in response to a request from a user. The LLC entity issues a SABME PDU² to request a logical connection with the other LLC entity. If the connection is accepted by the LLC user designated by the DSAP, then the destination LLC entity returns an unnumbered acknowledgment (UA) PDU. The connection is henceforth uniquely identified by the pair of user SAPs. If the destination LLC user rejects the connection request, its LLC entity returns a disconnected mode (DM) PDU.

Once the connection is established, data are exchanged using information PDUs, as in HDLC. The information PDUs include send and receive sequence numbers, for sequencing and flow control. The supervisory PDUs are used, as in HDLC, for flow control and error control. Either LLC entity can terminate a logical LLC connection by issuing a disconnect (DISC) PDU.

With **type 3 operation**, each transmitted PDU is acknowledged. A new (not found in HDLC) unnumbered PDU, the Acknowledged Connectionless (AC) Information PDU, is defined. User data are sent in AC command PDUs and must be acknowledged using an AC response PDU. To guard against lost PDUs, a 1-bit sequence number is used. The sender alternates the use of 0 and 1 in its AC command PDU, and the receiver responds with an AC PDU with the opposite number of the corresponding command. Only one PDU in each direction may be outstanding at any time.

Medium Access Control

All LANs and MANs consist of collections of devices that must share the network's transmission capacity. Some means of controlling access to the transmission medium is needed to provide for an orderly and efficient use of that capacity. This is the function of a medium access control (MAC) protocol.

The key parameters in any medium access control technique are where and how. *Where* refers to whether control is exercised in a centralized or distributed fashion. In a centralized scheme, a controller is designated that has the authority to grant access to the network. A station wishing to transmit must wait until it receives permission from the controller. In a decentralized network, the stations collectively perform a medium access control function to determine dynamically the order in

Ordenado
uso Eficiente de la
Capacidad.

Control.
Donde?
Como?

²This stands for Set Asynchronous Balanced Mode Extended. It is used in HDLC to choose ABM and to select extended sequence numbers of seven bits. Both ABM and 7-bit sequence numbers are mandatory in type 2 operation.

which stations transmit. A centralized scheme has certain advantages, including the following:

- It may afford greater control over access for providing such things as priorities, overrides, and guaranteed capacity.
- It enables the use of relatively simple access logic at each station.
- It avoids problems of distributed coordination among peer entities.

The principal disadvantages of centralized schemes are as follows:

- It creates a single point of failure; that is, there is a point in the network that, if it fails, causes the entire network to fail.
- It may act as a bottleneck, reducing performance.

The pros and cons of distributed schemes are mirror images of the points just made.

The second parameter, *how*, is constrained by the topology and is a trade-off among competing factors, including cost, performance, and complexity. In general, we can categorize access control techniques as being either synchronous or asynchronous. With synchronous techniques, a specific capacity is dedicated to a connection. This is the same approach used in circuit switching, frequency-division multiplexing (FDM), and synchronous time-division multiplexing (TDM). Such techniques are generally not optimal in LANs and MANs because the needs of the stations are unpredictable. It is preferable to be able to allocate capacity in an asynchronous (dynamic) fashion, more or less in response to immediate demand. The asynchronous approach can be further subdivided into three categories: round robin, reservation, and contention.

ROUND ROBIN With round robin, each station in turn is given the opportunity to transmit. During that opportunity, the station may decline to transmit or may transmit subject to a specified upper bound, usually expressed as a maximum amount of data transmitted or time for this opportunity. In any case, the station, when it is finished, relinquishes its turn, and the right to transmit passes to the next station in logical sequence. Control of sequence may be centralized or distributed. Polling is an example of a centralized technique.

When many stations have data to transmit over an extended period of time, round-robin techniques can be very efficient. If only a few stations have data to transmit over an extended period of time, then there is a considerable overhead in passing the turn from station to station, because most of the stations will not transmit but simply pass their turns. Under such circumstances other techniques may be preferable, largely depending on whether the data traffic has a stream or bursty characteristic. Stream traffic is characterized by lengthy and fairly continuous transmissions; examples are voice communication, telemetry, and bulk file transfer. Bursty traffic is characterized by short, sporadic transmissions; interactive terminal-host traffic fits this description.

RESERVATION For stream traffic, reservation techniques are well suited. In general, for these techniques, time on the medium is divided into slots, much as with synchronous TDM. A station wishing to transmit reserves future slots for an extended

¿Como?

¿Tecnicas Asíncorno
o Sincrono?

¿FDM o TDM?

Asíncrono.
-round robin.
-Reserva
-Contienda



Token Ring





or even an indefinite period. Again, reservations may be made in a centralized or distributed fashion.

CONTENTION For bursty traffic, contention techniques are usually appropriate. With these techniques, no control is exercised to determine whose turn it is; all stations contend for time in a way that can be, as we shall see, rather rough and tumble. These techniques are of necessity distributed in nature. Their principal advantage is that they are simple to implement and, under light-to-moderate load, efficient. For some of these techniques, however, performance tends to collapse under heavy load.

Although both centralized and distributed reservation techniques have been implemented in some LAN products, round-robin and contention techniques are the most common.

MAC FRAME FORMAT The MAC layer receives a block of data from the LLC layer and is responsible for performing functions related to medium access and for transmitting the data. As with other protocol layers, MAC implements these functions making use of a protocol data unit at its layer. In this case, the PDU is referred to as a MAC frame.

The exact format of the MAC frame differs somewhat for the various MAC protocols in use. In general, all of the MAC frames have a format similar to that of Figure 11.5. The fields of this frame are as follows:

- **MAC Control:** This field contains any protocol control information needed for the functioning of the MAC protocol. For example, a priority level could be indicated here.
- **Destination MAC Address:** The destination physical attachment point on the LAN for this frame.
- **Source MAC Address:** The source physical attachment point on the LAN for this frame.
- **LLC:** The LLC data from the next higher layer.
- **CRC:** The Cyclic Redundancy Check field (also known as the Frame Check Sequence, FCS, field). This is an error-detecting code, as we have seen in HDLC and other data link control protocols (Chapter 7).

In most data link control protocols, the data link protocol entity is responsible not only for detecting errors using the CRC, but for recovering from those errors by retransmitting damaged frames. In the LAN protocol architecture, these two functions are split between the MAC and LLC layers. The MAC layer is responsible for detecting errors and discarding any frames that are in error. The LLC layer optionally keeps track of which frames have been successfully received and retransmits unsuccessful frames.

11.3 BRIDGES

In virtually all cases, there is a need to expand beyond the confines of a single LAN, to provide interconnection to other LANs and to wide area networks. Two general approaches are used for this purpose: bridges and routers. The **bridge** is the

¿En que capa está el Bridge?

```

tinet 172.18.0.1 netmask 255.255.0.0 broadcast 172.18.255.255
ether 02:42:9b:3c:d1:e8 txqueuelen 0 (Ethernet)
RX packets 0 bytes 0 (0.0 B)
RX errors 0 dropped 0 overruns 0 frame 0
TX packets 0 bytes 0 (0.0 B)
TX errors 0 dropped 0 overruns 0 carrier 0 collisions 0
  
```

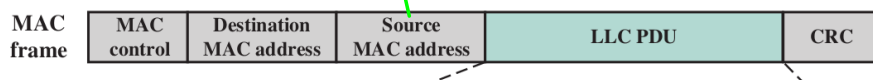

ver que el Bridge interconecta LAN Similares.
 Que quiere decir con similares?
 Por que tienen que se similares?

simpler of the two devices and provides a means of interconnecting similar LANs. The router is a more general-purpose device, capable of interconnecting a variety of LANs and WANs. We explore bridges in this section and look at routers in Part Five.

The bridge is designed for use between local area networks that use identical protocols for the physical and link layers (e.g., all conforming to IEEE 802.3). Because the devices all use the same protocols, the amount of processing required at the bridge is minimal. More sophisticated bridges are capable of mapping from one MAC format to another (e.g., to interconnect an Ethernet and a token ring LAN).

Because the bridge is used in a situation in which all the LANs have the same characteristics, the reader may ask, why not simply have one large LAN? Depending on circumstance, there are several reasons for the use of multiple LANs connected by bridges:



- **Reliability:** The danger in connecting all data processing devices in an organization to one network is that a fault on the network may disable communication for all devices. By using bridges, the network can be partitioned into self-contained units.



- **Performance:** In general, performance on a LAN declines with an increase in the number of devices or the length of the wire. A number of smaller LANs will often give improved performance if devices can be clustered so that intranetwork traffic significantly exceeds internetwork traffic.



- **Security:** The establishment of multiple LANs may improve security of communications. It is desirable to keep different types of traffic (e.g., accounting, personnel, strategic planning) that have different security needs on physically separate media. At the same time, the different types of users with different levels of security need to communicate through controlled and monitored mechanisms.

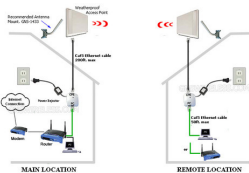

- **Geography:** Clearly, two separate LANs are needed to support devices clustered in two geographically distant locations. Even in the case of two buildings separated by a highway, it may be far easier to use a microwave bridge link than to attempt to string coaxial cable between the two buildings.

Functions of a Bridge

ver que NO Existe direcciones de capa 3 o IP!!

EXAMPLE 11.2 Figure 11.6 illustrates the action of a bridge connecting two LANs, A and B, using the same MAC protocol. In this example, a single bridge attaches to both LANs; frequently, the bridge function is performed by two “half-bridges,” one on each LAN. The functions of the bridge are few and simple:

- Read all frames transmitted on A and accept those addressed to any station on B.
- Using the medium access control protocol for B, retransmit each frame on B.
- Do the same for B-to-A traffic.

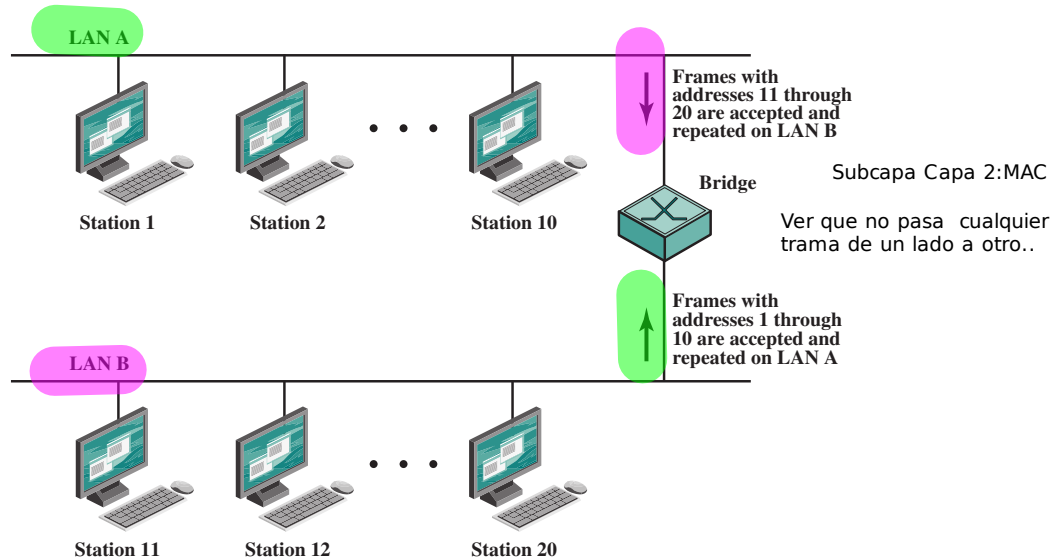

Figure 11.6 Bridge Operation

Several design aspects of a bridge are worth highlighting:

No toca, solo re-envía una copia por otra interface.



no procesa=> sencillo y rápido!

Pequeño conocimiento de ubicación de direcciones físicas.

Punto a punto o multipunto

- **The bridge makes no modification to the content or format of the frames it receives, nor does it encapsulate them with an additional header.** Each frame to be transferred is simply copied from one LAN and repeated with exactly the same bit pattern on the other LAN. Because the two LANs use the same LAN protocols, it is permissible to do this.
- **The bridge should contain enough buffer space to meet peak demands.** Over a short period of time, frames may arrive faster than they can be retransmitted.
- **The bridge must contain addressing and routing intelligence.** At a minimum, the bridge must know which addresses are on each network to know which frames to pass. Further, there may be more than two LANs interconnected by a number of bridges. In that case, a frame may have to be routed through several bridges in its journey from source to destination.
- **A bridge may connect more than two LANs.**

In summary, the bridge provides an extension to the LAN that requires no modification to the communications software in the stations attached to the LANs. It appears to all stations on the two (or more) LANs that there is a single LAN on which each station has a unique address. The station uses that unique address and need not explicitly discriminate between stations on the same LAN and stations on other LANs; the bridge takes care of that.

Bridge Protocol Architecture

The IEEE 802.1D specification defines the protocol architecture for MAC bridges. Within the 802 architecture, the endpoint or station address is designated at the

Ver que en cada Nodo, la trama sube en la pila de protocolos hasta la capa que pueda interpretar el contenido y luego se re-arma y baja para la interface que corresponde.

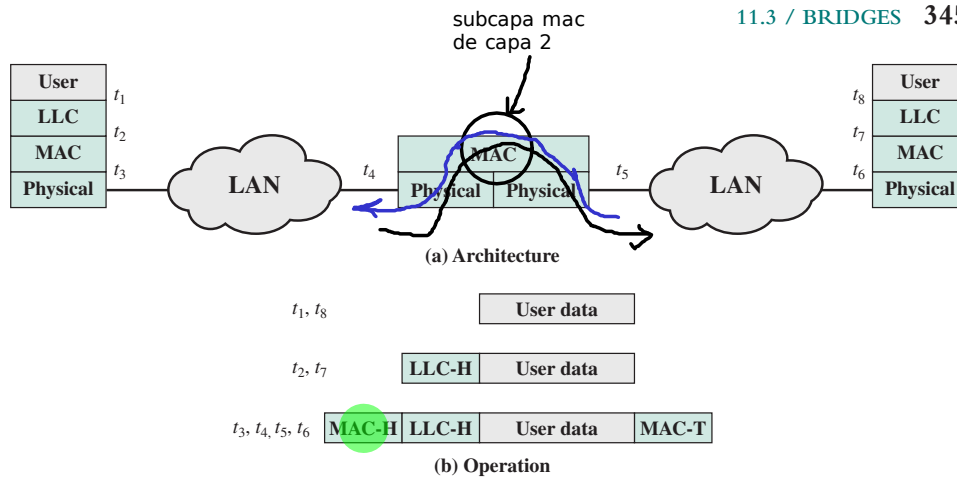

Figure 11.7 Connection of Two LANs by a Bridge

MAC level. Thus, it is at the MAC level that a bridge can function. Figure 11.7 shows the simplest case, which consists of two LANs connected by a single bridge. The LANs employ the same MAC and LLC protocols. The bridge operates as previously described. A MAC frame whose destination is not on the immediate LAN is captured by the bridge, buffered briefly, and then transmitted on the other LAN. As far as the LLC layer is concerned, there is a dialogue between peer LLC entities in the two endpoint stations. The bridge need not contain an LLC layer because it is merely serving to relay the MAC frames.

Figure 11.7b indicates the way in which data are encapsulated using a bridge. Data are provided by some user to LLC. The LLC entity appends a header and passes the resulting data unit to the MAC entity, which appends a header and a trailer to form a MAC frame. On the basis of the destination MAC address in the frame, it is captured by the bridge. The bridge does not strip off the MAC fields; its function is to relay the MAC frame intact to the destination LAN. Thus, the frame is deposited on the destination LAN and captured by the destination station.

The concept of a MAC relay bridge is not limited to the use of a single bridge to connect two nearby LANs. If the LANs are some distance apart, then they can be connected by two bridges that are in turn connected by a communications facility. The intervening communications facility can be a network, such as a wide area packet-switching network, or a point-to-point link. In such cases, when a bridge captures a MAC frame, it must encapsulate the frame in the appropriate packaging and transmit it over the communications facility to a target bridge. The target bridge strips off these extra fields and transmits the original, unmodified MAC frame to the destination station.

Fixed Routing

There is a trend within many organizations to an increasing number of LANs interconnected by bridges. As the number of LANs grows, it becomes important to provide alternate paths between LANs via bridges for load balancing and

reconfiguration in response to failure. Thus, many organizations will find that static, preconfigured routing tables are inadequate and that some sort of dynamic routing is needed.

EXAMPLE 11.3 Consider the configuration of Figure 11.8. Suppose that station 1 transmits a frame on LAN A intended for station 6. The frame will be read by bridges 101, 102, and 107. For each bridge, ~~the addressed station is not on a LAN to which the bridge is attached.~~ Therefore, each bridge must make a decision ~~whether or not to retransmit the frame on its other LAN,~~ in order to move it closer to its intended destination. In this case, bridge 102 should repeat the frame on LAN C, whereas bridges 101 and 107 should refrain from retransmitting the frame. Once the frame has been transmitted on LAN C, it will be picked up by both bridges 105 and 106. Again, each must decide whether or not to forward the frame. In this case, bridge 105 should retransmit the frame on LAN F, where it will be received by the destination, station 6.

Thus we see that, in the general case, ~~the bridge must be equipped with a routing capability.~~ When a bridge receives a frame, ~~it must decide whether or not to forward it.~~ If the bridge is attached to two or more networks, then it must decide whether or not to forward the frame and, if so, on which LAN the frame should be transmitted.

Ver que 101, 107 102 no saben si está ST6 en su alcance.

Ver que 101,102,107 deben retransmitir para ver si encuentran en destino...

105 si sabe de ST6

103,104,106 no saben de ST6

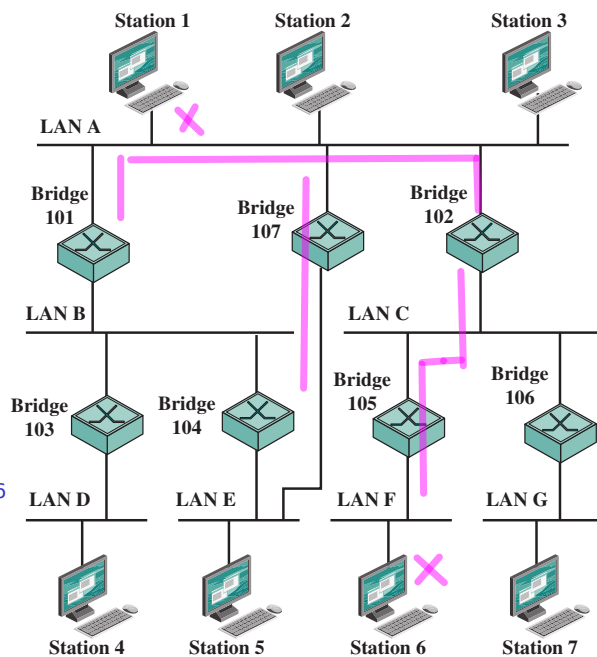

Figure 11.8 Configuration of Bridges and LANs, with Alternate Routes

TP (del inglés Spanning Tree Protocol) es un protocolo de red de capa 2 del modelo OSI (capa de enlace de datos). Su función es la de gestionar la presencia de bucles en topologías de red debido a la existencia de enlaces redundantes (necesarios en muchos casos para garantizar la disponibilidad de las conexiones)

Este algoritmo es el algoritmo de ruteo mas común en los Bridges.

Estandar redactado en IEEE 802.1

load balancing

The routing decision may not always be a simple one. Figure 11.8 also shows that there are two routes between LAN A and LAN E. Such redundancy provides for higher overall Internet availability and creates the possibility for load balancing. In this case, if station 1 transmits a frame on LAN A intended for station 5 on LAN E, then either bridge 101 or bridge 107 could forward the frame. It would appear preferable for bridge 107 to forward the frame, since it will involve only one hop, whereas if the frame travels through bridge 101, it must suffer two hops. Another consideration is that there may be changes in the configuration. For example, bridge 107 may fail, in which case subsequent frames from station 1 to station 5 should go through bridge 101. So we can say that the routing capability must take into account the topology of the internet configuration and may need to be dynamically altered.

A variety of routing strategies have been proposed and implemented in recent years. The simplest and most common strategy is fixed routing. This strategy is suitable for small internets and for internets that are relatively stable. In addition, two groups within the IEEE 802 committee have developed specifications for routing strategies. The IEEE 802.1 group has issued a standard for routing based on the use of a spanning tree algorithm. The token ring committee, IEEE 802.5, has issued its own specification, referred to as source routing. In the remainder of this section, we look at fixed routing and the spanning tree algorithm, which is the most commonly used bridge routing algorithm.

ruteo de origen para 802.5

For fixed routing, a route is selected for each source–destination pair of LANs in the configuration. If alternate routes are available between two LANs, then typically the route with the least number of hops is selected. The routes are fixed, or at least only change when there is a change in the topology of the internet.

Tengo que tener foto de la topología => esto se almacena en un tabla.

The strategy for developing a fixed routing configuration for bridges is similar to that employed in a packet-switching network. A central routing matrix is created, to be stored perhaps at a network control center. The matrix shows, for each source–destination pair of LANs, the identity of the first bridge on the route.

EXAMPLE 11.4 The route from LAN E to LAN F begins by going through bridge 107 to LAN A. Again consulting the matrix, the route from LAN A to LAN F goes through bridge 102 to LAN C. Finally, the route from LAN C to LAN F is directly through bridge 105. Thus, the complete route from LAN E to LAN F is bridge 107, LAN A, bridge 102, and LAN C, bridge 105.

From this overall matrix, routing tables can be developed and stored at each bridge. Each bridge needs one table for each LAN to which it attaches. The information for each table is derived from a single row of the matrix. Thus, bridge 105 has two tables, one for frames arriving from LAN C and one for frames arriving from LAN F. The table shows, for each possible destination MAC address, the identity of the LAN to which the bridge should forward the frame.

Once the directories have been established, routing is a simple matter. A bridge copies each incoming frame on each of its LANs. If the destination MAC address corresponds to an entry in its routing table, the frame is retransmitted on the appropriate LAN.

The fixed routing strategy is widely used in commercially available products. It requires that a network manager manually load the data into the routing tables. It has the advantage of simplicity and minimal processing requirements. However, in a complex internet, in which bridges may be dynamically added and in which failures must be allowed for, this strategy is too limited.

The Spanning Tree Approach : mecanismo para encontrar ruta que puede cambiar...

The spanning tree approach is a mechanism in which bridges automatically develop a routing table and update that table in response to changing topology. The algorithm consists of three mechanisms: frame forwarding, address learning, and loop resolution.

Algoritmo tiene 3 formas...

- 1 **FRAME FORWARDING** In this scheme, a bridge maintains a forwarding database for each port attached to a LAN. The database indicates the station addresses for which frames should be forwarded through that port. We can interpret this in the following fashion. For each port, a list of stations is maintained. A station is on the list if it is on the "same side" of the bridge as the port. For example, for bridge 102 of Figure 11.8, stations on LANs C, F, and G are on the same side of the bridge as the LAN C port, and stations on LANs A, B, D, and E are on the same side of the bridge as the LAN A port. When a frame is received on any port, the bridge must decide whether that frame is to be forwarded through the bridge and out through one of the bridge's other ports. Suppose that a bridge receives a MAC frame on port x . The following rules are applied:

la base de datos indica por que puerto debe ser encaminado para llegar al destino deseado.

1. Search the forwarding database to determine if the MAC address is listed for any port except port x .
2. If the destination MAC address is not found, forward frame out all ports except the one from which it was received. This is part of the learning process described subsequently.

Broadcast

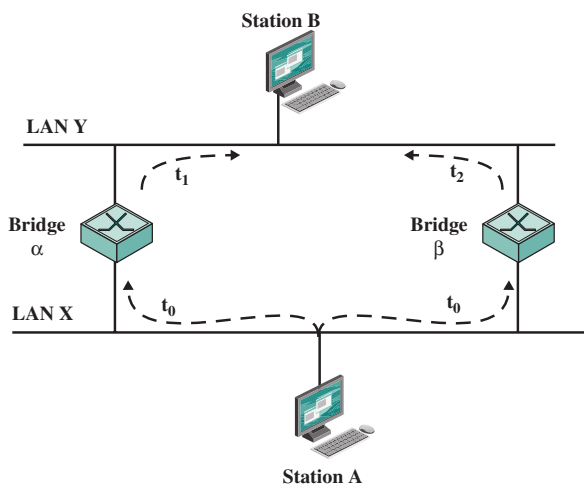
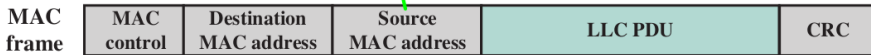

Figure 11.9 Loop of Bridges



3. If the destination address is in the forwarding database for some port y , then determine whether port y is in a blocking or forwarding state. For reasons explained later, a port may sometimes be blocked, which prevents it from receiving or transmitting frames.
4. If port y is not blocked, transmit the frame through port y onto the LAN to which that port attaches.

2 **ADDRESS LEARNING** The preceding scheme assumes that the bridge is already equipped with a forwarding database that indicates the direction, from the bridge, of each destination station. This information can be preloaded into the bridge, as in fixed routing. However, an effective automatic mechanism for learning the direction of each station is desirable. A simple scheme for acquiring this information is based on the use of the Source Address field in each MAC frame.

Agenda el origen, con eso sabe el puerto por el que vino

No plantea la posibilidad de rutas alternativas

The strategy is this. When a frame arrives on a particular port, it clearly has come from the direction of the incoming LAN. The Source Address field of the frame indicates the source station. Thus, a bridge can update its forwarding database for that port on the basis of the Source Address field of each incoming frame. To allow for changes in topology, each element in the database is equipped with a timer. When a new element is added to the database, its timer is set. If the timer expires, then the element is eliminated from the database, since the corresponding direction information may no longer be valid. Each time a frame is received, its source address is checked against the database. If the element is already in the database, the entry is updated (the direction may have changed) and the timer is reset. If the element is not in the database, a new entry is created, with its own timer.

3 **SPANNING TREE ALGORITHM** The address learning mechanism described previously is effective if the topology of the internet is a tree, that is, if there are no alternate routes in the network. The existence of alternate routes means that there is a closed loop. For example in Figure 11.8, the following is a closed loop: LAN A, bridge 101, LAN B, bridge 104, LAN E, bridge 107, LAN A.

To see the problem created by a closed loop, consider Figure 11.9. At time t_0 , station A transmits a frame addressed to station B. The frame is captured by both bridges. Each bridge updates its database to indicate that station A is in the direction of LAN X, and retransmits the frame on LAN Y. Say that bridge α retransmits at time t_1 and bridge β a short time later t_2 . Thus B will receive two copies of the frame. Furthermore, each bridge will receive the other's transmission on LAN Y. Note that each transmission is a frame with a source address of A and a destination address of B. Thus each bridge will update its database to indicate that station A is in the direction of LAN Y. Neither bridge is now capable of forwarding a frame addressed to station A.

To overcome this problem, a simple result from graph theory is used: For any connected graph, consisting of nodes and edges connecting pairs of nodes, there is a spanning tree of edges that maintains the connectivity of the graph but contains no closed loops. In terms of internets, each LAN corresponds to a graph node, and each bridge corresponds to a graph edge. Thus, in Figure 11.8, the removal of one (and only one) of bridges 107, 101, and 104 results in a spanning tree. What is desired is to develop a simple algorithm by which the bridges of the internet can exchange

Todo lo que se requiere es que a cada puente se le asigne un identificador único y que los costos se asignen a cada puerto del puente. En ausencia de consideraciones especiales, todos los costos podrían igualarse; esto produce un árbol de salto mínimo.

El algoritmo implica un breve intercambio de mensajes entre todos los puentes para descubrir el árbol de expansión de costo mínimo. Siempre que hay un cambio en la topología, los puentes recalculan automáticamente el árbol de expansión.

Si hay un empate se selecciona uno por algún criterio. Ver que aquí NO hay un bloqueo!!

350 CHAPTER 11 / LOCAL AREA NETWORK OVERVIEW

sufficient information to automatically (without user intervention) derive a spanning tree. **The algorithm must be dynamic.** That is, when a topology change occurs, the bridges must be able to discover this fact and automatically derive a new spanning tree.

The spanning tree algorithm developed by IEEE 802.1, as the name suggests, is able to develop such a spanning tree. All that is required is that **each bridge be assigned a unique identifier** and **that costs be assigned to each bridge port.** In the absence of any special considerations, all costs could be set equal; this produces a minimum-hop tree. The algorithm involves a brief exchange of messages among all of the bridges to discover the minimum-cost spanning tree. Whenever there is a change in topology, the bridges automatically recalculate the spanning tree.

For more information on the spanning tree algorithm, see Appendix J.

11.4 HUBS AND SWITCHES

In recent years, there has been a proliferation of types of devices for interconnecting LANs that goes beyond the bridges discussed in Section 11.3 and the routers discussed in Part Five. These devices can conveniently be grouped into the categories of hubs and switches.

Hubs

Earlier, we used the term **hub in reference to a star-topology LAN.** The hub is the active central element of the star layout. Each station is connected to the hub **by two lines (transmit and receive).** **The hub acts as a repeater.** When a single station transmits, the hub repeats the signal on the outgoing line to each station. Ordinarily, the line consists of two unshielded twisted pairs. **Because of the high data rate and the poor transmission qualities of unshielded twisted pair, the length of a line is limited to about 100 m.** As an alternative, an optical fiber link may be used. In this case, the **maximum length is about 500 m.**

Broadcast

y la técnica
CSMA/CD



Note that although this **scheme is physically a star, it is logically a bus:** A transmission from any one station is received by all other stations, **and if two stations transmit at the same time there will be a collision.**

Multiple levels of hubs can be cascaded in a hierarchical configuration. Figure 11.10 illustrates a two-level configuration. There is one **header hub (HHUB)** and one or more **intermediate hubs (IHUB).** Each hub may have a mixture of stations and other hubs attached to it from below. This layout fits well with building wiring practices. Typically, there is a wiring closet on each floor of an office building, and a hub can be placed in each one. Each hub could service the stations on its floor.

Layer 2 Switches Capa 2!!

In recent years, a new device, **the layer 2 switch, has replaced the hub in popularity,** particularly for high-speed LANs. The layer 2 **switch** is also sometimes referred to as a switching hub.

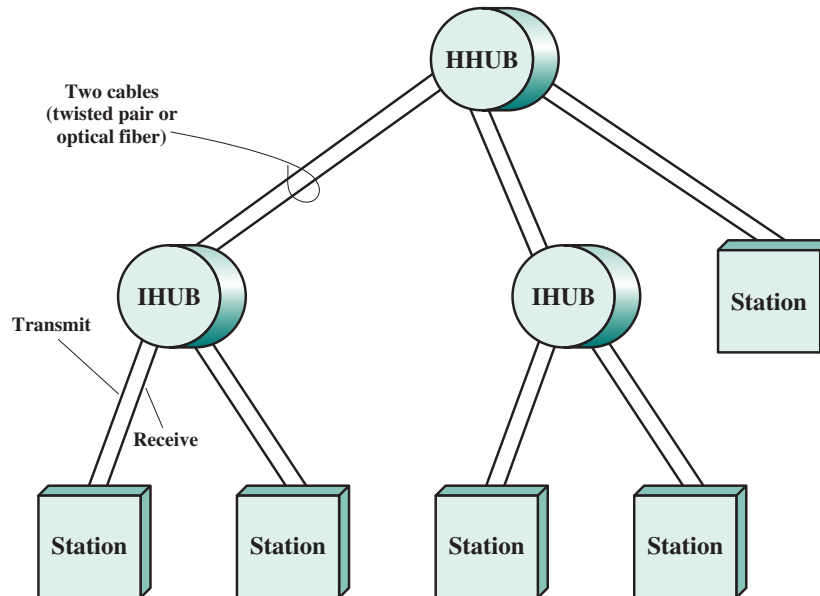

Figure 11.10 Two-Level Star Topology

To clarify the distinction between hubs and switches, Figure 11.11a shows a typical bus layout of a traditional 10-Mbps LAN. A bus is installed that is laid out so that all the devices to be attached are in reasonable proximity to a point on the bus. In the figure, station B is transmitting. This transmission goes from B, across the lead from B to the bus, along the bus in both directions, and along the access lines of each of the other attached stations. In this configuration, all the stations must share the total capacity of the bus, which is 10 Mbps.

A hub, often in a building wiring closet, uses a star wiring arrangement to attach stations to the hub. In this arrangement, a transmission from any one station is received by the hub and retransmitted on all of the outgoing lines. Therefore, to avoid collision, only one station can transmit at a time. Again, the total capacity of the LAN is 10 Mbps. The hub has several advantages over the simple bus arrangement. It exploits standard building wiring practices in the layout of cable. In addition, the hub can be configured to recognize a malfunctioning station that is jamming the network and to cut that station out of the network. Figure 11.11b illustrates the operation of a hub. Here again, station B is transmitting. This transmission goes from B, across the transmit line from B to the hub, and from the hub along the receive lines of each of the other attached stations.

We can achieve greater performance with a layer 2 switch. In this case, the central hub acts as a switch, much as a packet switch or circuit switch. **With a layer 2 switch, an incoming frame from a particular station is switched to the appropriate output line to be delivered to the intended destination.** At the same time, other unused lines can be used for switching other traffic. Figure 11.11c shows an example in which B is transmitting a frame to A and at the same time C is transmitting

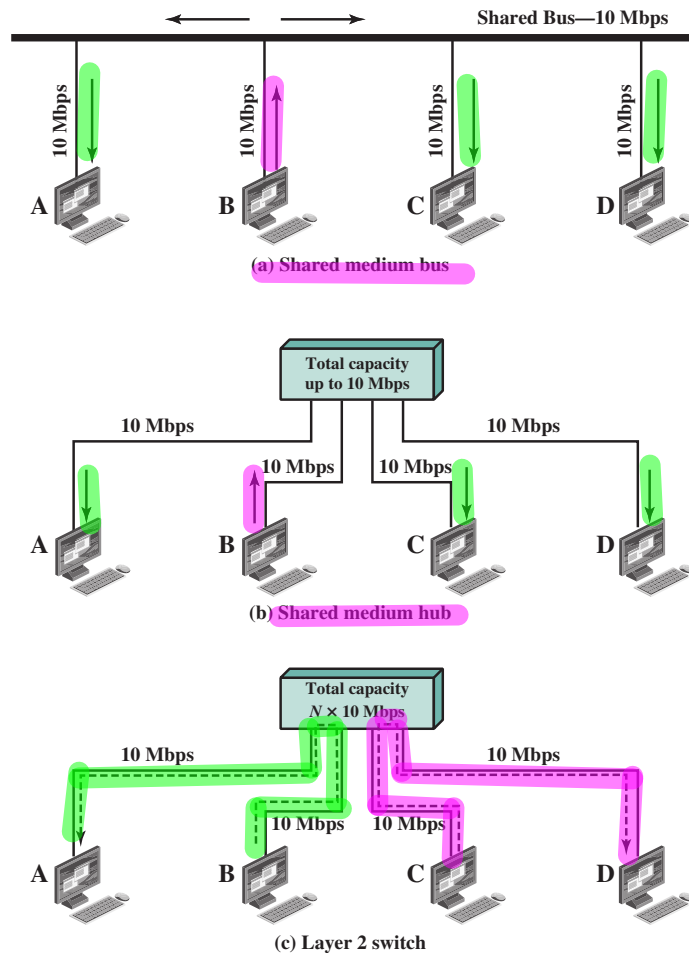

Figure 11.11 LAN Hubs and Switches

a frame to D. So, in this example, the current throughput on the LAN is 20 Mbps, although each individual device is limited to 10 Mbps. The layer 2 switch has several attractive features:

1. No change is required to the software or hardware of the attached devices to convert a bus LAN or a hub LAN to a switched LAN. In the case of an Ethernet LAN, each attached device continues to use the Ethernet medium access control protocol to access the LAN. From the point of view of the attached devices, nothing has changed in the access logic.
2. Each attached device has a dedicated capacity equal to that of the entire original LAN, assuming that the layer 2 switch has sufficient capacity to keep up with all attached devices. For example, in Figure 11.11c, if the layer 2 switch

can sustain a throughput of 20 Mbps, each attached device appears to have a dedicated capacity for either input or output of 10 Mbps.

3. The layer 2 switch scales easily. Additional devices can be attached to the layer 2 switch by increasing the capacity of the layer 2 switch correspondingly.

Two types of layer 2 switches are available as commercial products:

- **Store-and-forward switch:** The layer 2 switch accepts a frame on an input line, buffers it briefly, and then routes it to the appropriate output line.
- **Cut-through switch:** The layer 2 switch takes advantage of the fact that the destination address appears at the beginning of the MAC frame. The layer 2 switch begins repeating the incoming frame onto the appropriate output line as soon as the layer 2 switch recognizes the destination address.

The cut-through switch yields the highest possible throughput but at some risk of propagating bad frames, because the switch is not able to check the CRC prior to retransmission. The store-and-forward switch involves a delay between sender and receiver but boosts the overall integrity of the network.

A layer 2 switch can be viewed as a full-duplex version of the hub. It can also incorporate logic that allows it to function as a multiport bridge. The following are differences between layer 2 switches and bridges:

- Bridge frame handling is done in software. A layer 2 switch performs the address recognition and frame forwarding functions in hardware.
- A bridge can typically only analyze and forward one frame at a time, whereas a layer 2 switch has multiple parallel data paths and can handle multiple frames at a time.
- A bridge uses store-and-forward operation. With a layer 2 switch, it is possible to have cut-through instead of store-and-forward operation.

Because a layer 2 switch has higher performance and can incorporate the functions of a bridge, the bridge has suffered commercially. New installations typically include layer 2 switches with bridge functionality rather than bridges.

11.5 VIRTUAL LANS

Figure 11.12 shows a relatively common type of hierarchical LAN configuration. In this example, the devices on the LAN are organized into four groups, each served by a LAN switch. The three lower groups might correspond to different departments, which are physically separated, and the upper group could correspond to a centralized server farm that is used by all the departments.

Let us consider the transmission of a single MAC frame from workstation X. Suppose the destination MAC address in the frame (see Figure 11.5) is workstation Y. This frame is transmitted from X to the local switch, which then directs the frame along the link to Y. If X transmits a frame addressed to Z or W, then its local switch routes the MAC frame through the appropriate switches to the intended

+ capacidad

como el Bridge, pero para cada puerto!!

cuando aparece la mac de destino., conmuta al puerto entonces no almacena TODA la trama.,

¿y si hay error en la trama?

Bridge: Software
Switch: Hardware

Bridge:
1 trama x vez.
Switch:
multiples tramas

Bridge solo store and forward. Switch aparte puede hacer cutthrough

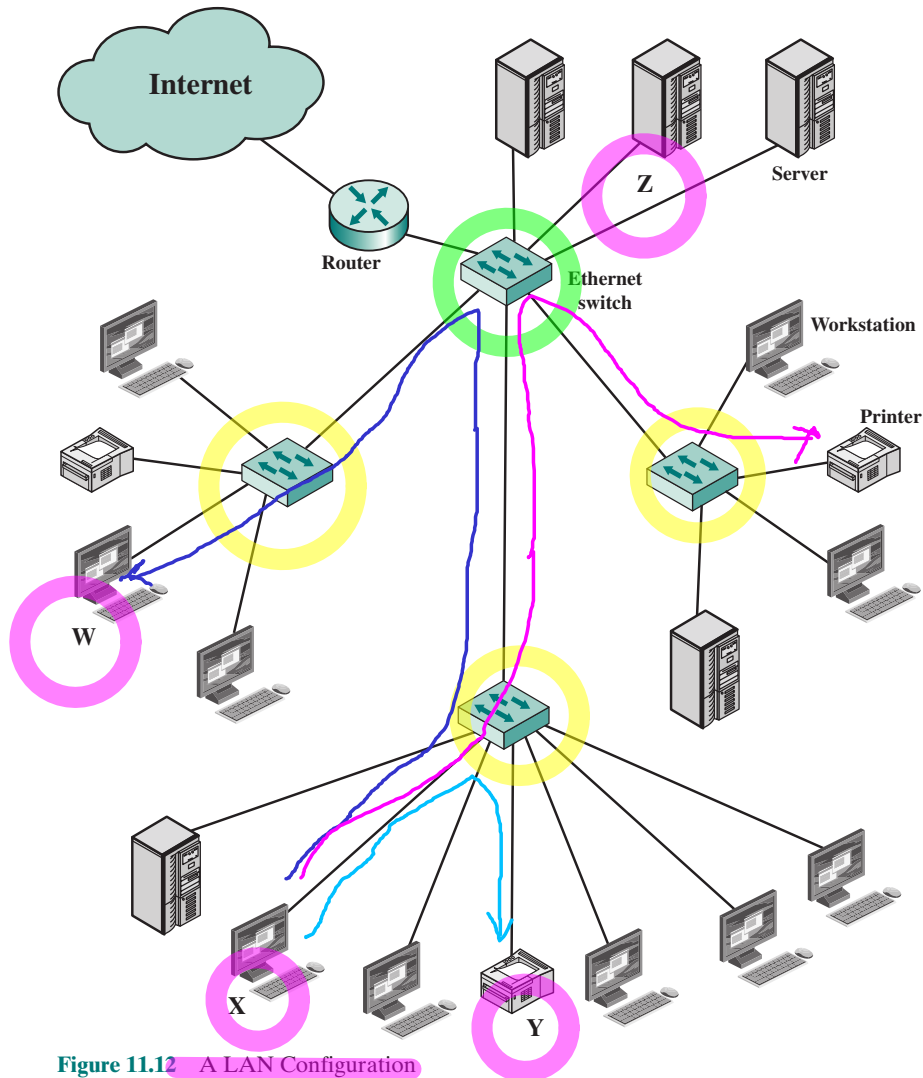

Figure 11.12 A LAN Configuration

destination. All these are examples of **unicast addressing**, in which the destination address in the MAC frame designates a unique destination. A MAC frame may also contain a **broadcast address**, in which case the destination MAC address indicates that all devices on the LAN should receive a copy of the frame. Thus, if X transmits a frame with a broadcast destination address, all of the devices on all of the switches in Figure 11.12 receive a copy of the frame. The total collection of devices that receive broadcast frames from each other is referred to as a **broadcast domain**.

In many situations, a broadcast frame is used for a purpose, such as network management or the transmission of some type of alert, that has a relatively local

FF:FF:FF:FF:FF

Broadcast domain:
colección de equipos
que reciben la trama

significance. Thus, in Figure 11.12, if a broadcast frame has information that is only useful to a particular department, then transmission capacity is wasted on the other portions of the LAN and on the other switches.

One simple approach to improving efficiency is to physically partition the LAN into separate broadcast domains, as shown in Figure 11.13. We now have four separate LANs connected by a router. In this case, an IP packet from X intended for Z is handled as follows. The IP layer at X determines that the next hop to the destination is via router V. This information is handed down to X's MAC layer, which prepares a MAC frame with a destination MAC address of router V. When V receives the frame, it strips off the MAC header, determines the destination, and

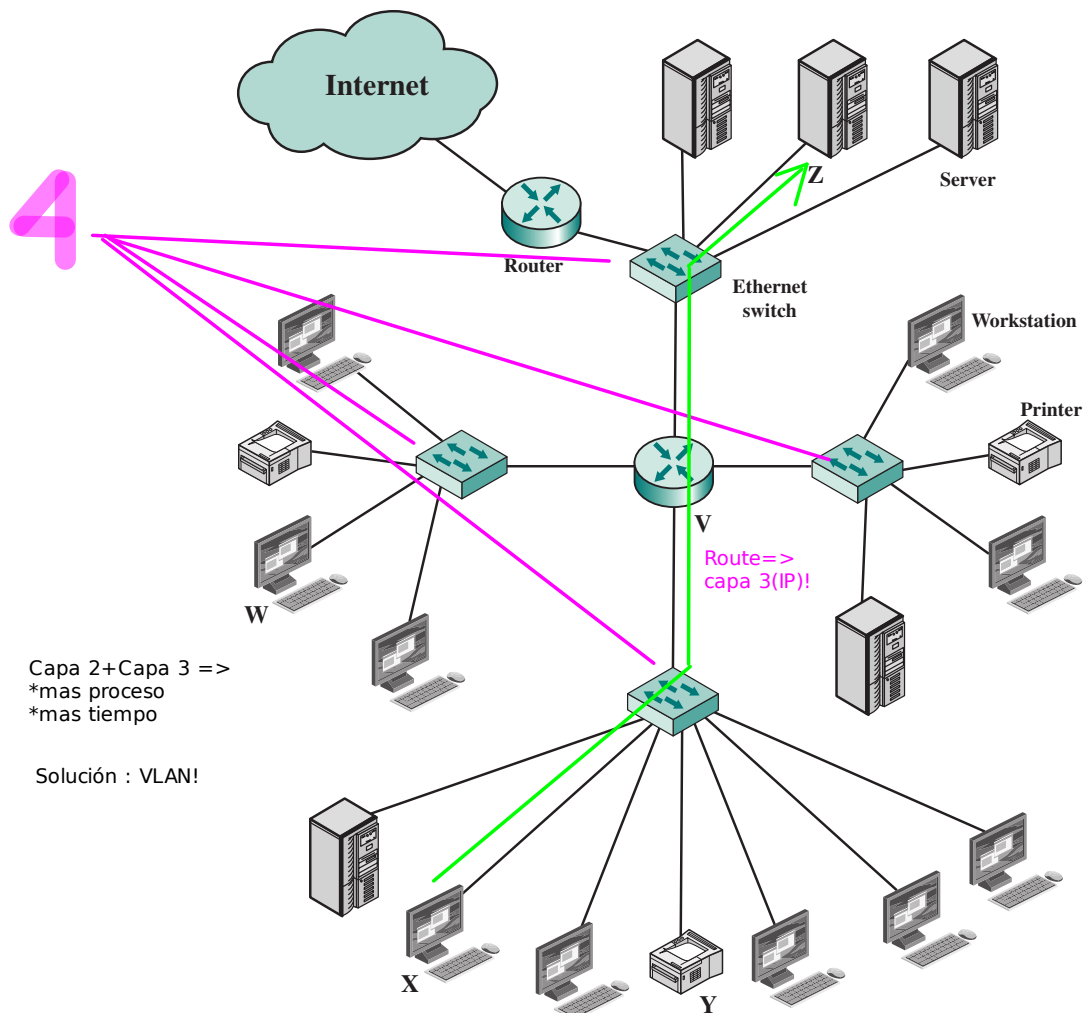

Figure 11.13 A Partitioned LAN

encapsulates the IP packet in a MAC frame with a destination MAC address of Z. This frame is then sent to the appropriate Ethernet switch for delivery.

The drawback to this approach is that the traffic pattern may not correspond to the physical distribution of devices. For example, some departmental workstations may generate a lot of traffic with one of the central servers. Further, as the networks expand, more routers are needed to separate users into broadcast domains and provide connectivity among broadcast domains. Routers introduce more latency than switches because the router must process more of the packet to determine destinations and route the data to the appropriate end node.

The Use of Virtual LANs

subgrupo lógico
red+estaciones en un solo dominio de broadcast
se implementa en los Switchs=> Sub capa Mac de Capa 2!

A more effective alternative is the creation of **virtual LANs (VLANs)**. In essence, a VLAN is a logical subgroup within a LAN that is created by software rather than by physically moving and separating devices. It combines user stations and network devices into a single broadcast domain regardless of the physical LAN segment they are attached to and allows traffic to flow more efficiently within populations of mutual interest. The VLAN logic is implemented in LAN switches and functions at the MAC layer. Because the objective is to isolate traffic within the VLAN, in order to link from one VLAN to another, a router is required. Routers can be implemented as separate devices, so that traffic from one VLAN to another is directed to a router, or the router logic can be implemented as part of the LAN switch, as shown in Figure 11.14.

VLANs provide the ability for any organization to be physically dispersed throughout the company while maintaining its group identity. For example, accounting personnel can be located on the shop floor, in the research and development center, in the cash disbursement office, and in the corporate offices while all members reside on the same virtual network, sharing traffic only with each other.

la idea es que no tienen que estar físicamente juntos para formar un grupo lógico o VLAN

In Figure 11.14, five VLANs are defined. A transmission from workstation X to server Z is within the same VLAN, so it is efficiently switched at the MAC level. A broadcast MAC frame from X is transmitted to all devices in all portions of the same VLAN. But a transmission from X to printer Y goes from one VLAN to another. Accordingly, router logic at the IP level is required to move the IP packet from X to Y. In Figure 11.14, that logic is integrated into the switch, so that the switch determines whether or not the incoming MAC frame is destined for another device on the same VLAN. If not, the switch routes the enclosed IP packet at the IP level.

Defining VLANs

A VLAN is a broadcast domain consisting of a group of end stations, perhaps on multiple physical LAN segments, that are not constrained by their physical location and can communicate as if they were on a common LAN. Some means is therefore needed for defining VLAN membership. A number of different approaches have been used for defining membership, including the following:

¿Como definimos que equipos pertenecen a una misma VLAN?

- **Membership by port group:** Each switch in the LAN configuration contains two types of ports: a trunk port, which connects two switches, and an end port, which connects the switch to an end system. A VLAN can be defined by

troncal
no troncal



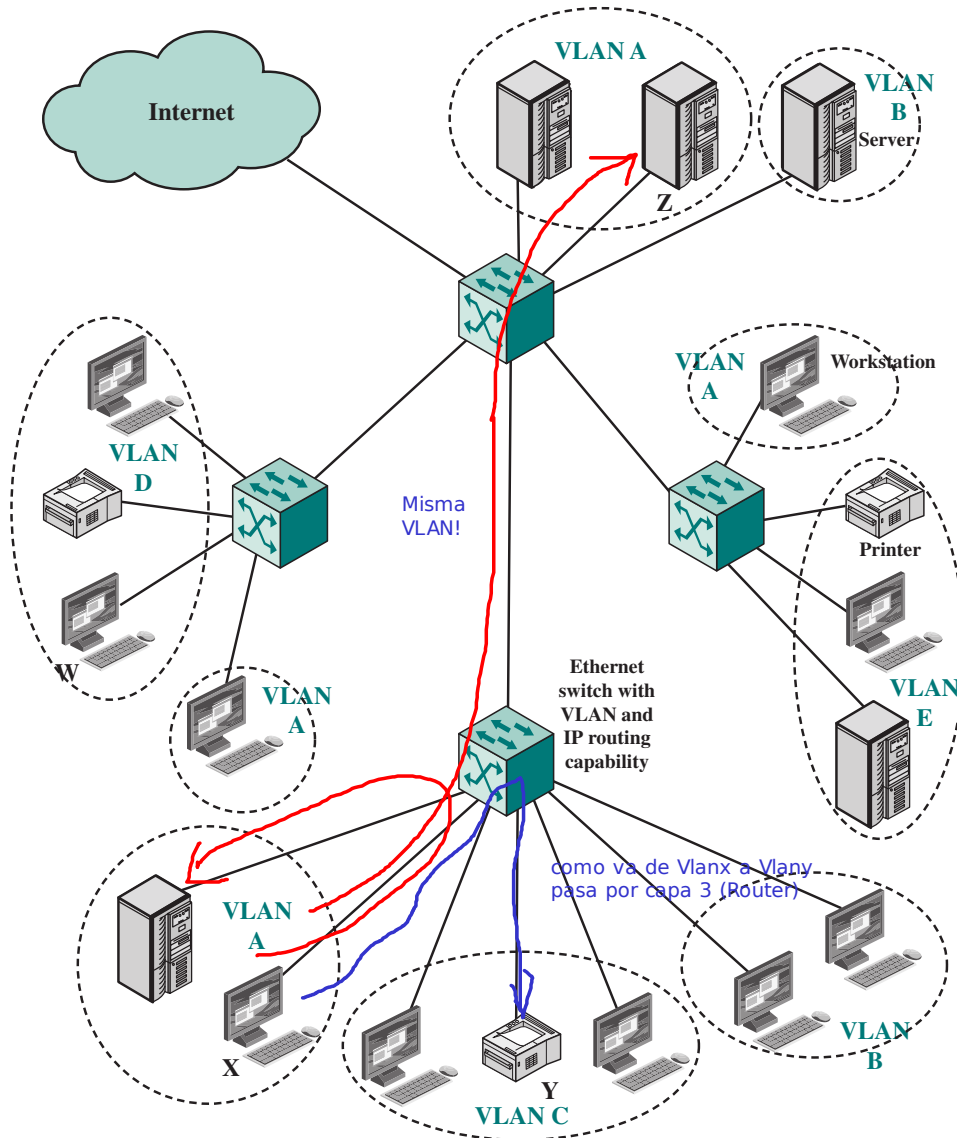
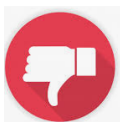

Figure 11.14 A VLAN Configuration

assigning each end port to a specific VLAN. This approach has the advantage that it is relatively easy to configure. The principle disadvantage is that the network manager must reconfigure VLAN membership when an end system moves from one port to another.



- **Membership by MAC address:** Since MAC-layer addresses are hardwired into the workstation's network interface card (NIC), VLANs based on MAC

addresses enable network managers to move a workstation to a different physical location on the network and have that workstation automatically retain its VLAN membership. The main problem with this method is that **VLAN membership must be assigned initially**. In networks with thousands of users, this is no easy task. Also, **in environments where notebook PCs are used**, the MAC address is associated with the docking station and not with the notebook PC. Consequently, when a notebook PC is moved to a different docking station, its VLAN membership must be reconfigured.



- **Membership based on protocol information:** VLAN membership can be assigned based on IP address, transport protocol information, or even higher-layer protocol information. This is a quite flexible approach, but it does require switches to examine portions of the MAC frame above the MAC layer, which may have a performance impact.

Communicating VLAN Membership

Switches must have a way of understanding VLAN membership (i.e., which stations belong to which VLAN) when network traffic arrives from other switches; otherwise, VLANs would be limited to a single switch. One possibility is to configure the information manually or with some type of network management signaling protocol, so that switches can associate incoming frames with the appropriate VLAN.

A more common approach is **frame tagging**, in which a header is typically inserted into each frame on interswitch trunks to uniquely identify to which VLAN a particular MAC-layer frame belongs. The IEEE 802 committee has developed a standard for frame tagging, **IEEE 802.1Q**, which we examine in the next chapter.

11.6 RECOMMENDED READING AND ANIMATIONS

[RAJA97] is a good summary of VLAN principles.

RAJA97 Rajaravivarma, V. “Virtual Local Area Network Technology and Applications.” *Proceedings, 29th Southeastern Symposium on System Theory*, 1997.



Animations

Animations that illustrate LAN concepts are available at the Premium Web site. The reader is encouraged to view these animations to reinforce concepts from this chapter.

11.7 KEY TERMS, REVIEW QUESTIONS, AND PROBLEMS

Key Terms

bridge	hub	spanning tree
broadcast address	intermediate hubs (IHUB)	star topology
broadcast domain	layer 2 switch	switch
bus topology	local area network (LAN)	type 1 operation
connectionless service	logical link control (LLC)	type 2 operation
connection-mode service	medium access control	type 3 operation
fixed routing	(MAC)	unicast addressing
forwarding database	physical layer	virtual LAN (VLAN)
header hub (HHUB)	source routing	

Review Questions

- 11.1** What is network topology?
- 11.2** List four common LAN topologies and briefly describe their methods of operation.
- 11.3** What is the purpose of the IEEE 802 committee?
- 11.4** Why are there multiple LAN standards?
- 11.5** List and briefly define the services provided by LLC.
- 11.6** List and briefly define the types of operation provided by the LLC protocol.
- 11.7** List some basic functions performed at the MAC layer.
- 11.8** What functions are performed by a bridge?
- 11.9** What is a spanning tree?
- 11.10** What is the difference between a hub and a layer 2 switch?
- 11.11** What is the difference between a store-and-forward switch and a cut-through switch?

Problems

- 11.1** Instead of LLC, could HDLC be used as a data link control protocol for a LAN? If not, what is lacking?
- 11.2** An asynchronous device, such as a teletype, transmits characters one at a time with unpredictable delays between characters. What problems, if any, do you foresee if such a device is connected to a LAN and allowed to transmit at will (subject to gaining access to the medium)? How might such problems be resolved?
- 11.3** Consider the transfer of a file containing one million 8-bit characters from one station to another. What is the total elapsed time and effective throughput for the following cases:
 - a.** A circuit-switched, star-topology local network. Call setup time is negligible and the data rate on the medium is 64 kbps.
 - b.** A bus topology local network with two stations a distance D apart, a data rate of B bps, and a frame size of P with 80 bits of overhead per frame. Each frame is acknowledged with an 88-bit frame before the next is sent. The propagation speed on the bus is 200 m/ μ s. Solve for:

1. $D = 1 \text{ km}$, $B = 1 \text{ Mbps}$, $P = 256 \text{ bits}$
 2. $D = 1 \text{ km}$, $B = 10 \text{ Mbps}$, $P = 256 \text{ bits}$
 3. $D = 10 \text{ km}$, $B = 1 \text{ Mbps}$, $P = 256 \text{ bits}$
 4. $D = 1 \text{ km}$, $B = 50 \text{ Mbps}$, $P = 10,000 \text{ bits}$
- 11.4** Consider a baseband bus with a number of equally spaced stations with a data rate of 10 Mbps and a bus length of 1 km.
- a. What is the mean time to send a frame of 1000 bits to another station, measured from the beginning of transmission to the end of reception? Assume a propagation speed of 200 m/ μ s.
 - b. If two stations begin to transmit at exactly the same time, their packets will interfere with each other. If each transmitting station monitors the bus during transmission, how long before it notices an interference, in seconds? In bit times?
- 11.5** Repeat Problem 15.4 for a data rate of 100 Mbps.
- 11.6** Draw figures similar to Figure 11.7 for a configuration in which
- a. Two LANs are connected via two bridges that are connected by a point-to-point link.
 - b. Two LANs are connected via two bridges that are connected by an ATM packet-switching network.
- 11.7** For the configuration of Figure 11.8, show the central routing matrix and the routing tables at each bridge.
- 11.8** Develop a spanning tree for the configuration of Figure 11.15.
- 11.9** A station on a LAN that includes an attached bridge sends out a frame to a device that is not present on any of the segments of the total network. What does the bridge do with this frame?

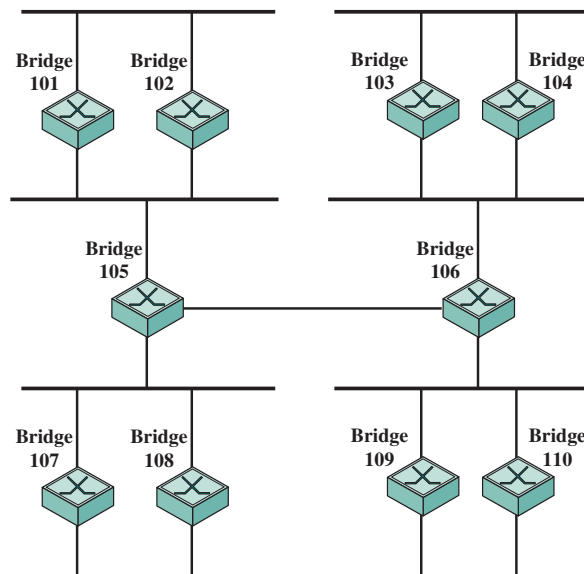

Figure 11.15 Configuration of Problem 11.8